

**OPERATIONS MANUAL**  
**PCM-DSP10**  
**PCM-J1708**

WinSystems reserves the right to make changes in circuitry  
and specifications at any time without notice.  
© Copyright 1996 WinSystems®. All Rights Reserved.

**REVISION HISTORY**

**P/N 403-0247-000**

ECO Number	Date Code	Revision
ORIGINATED	960508	A
98-88	980826	A1
98-105	981117	A2

# TABLE OF CONTENTS

<b>Section</b>	<b>Paragraph Title</b>	<b>Page</b>
	<b>Visual Index – Quick Reference</b>	
1	General Information	1-1
1.1	Features	1-1
1.2	General Description	1-1
1.3	Specifications	1-2
2	PCM-DSPIO Technical Reference	2-1
2.1	Introduction	2-1
2.2	Serial I/O Address Selection	2-1
2.3	Serial Interrupt Selection	2-2
2.4	RS- 232 Mode Configuration	2-2
2.5	RS- 422 Mode Configuration	2-3
2.6	RS- 485 Mode Configuration	2-5
2.7	SAE J1708 Mode Configuration	2-7
2.8	Parallel Port I/O Address Selection	2-8
2.9	Parallel Port Direction Control	2-9
2.10	Parallel Port Interrupt Routing Selection	2-9
2.11	Parallel Port I/O Connector Pinout	2-9
2.12	PC/104 Bus Connectors	2-10
2.13	Connector/Jumper Summary	2-11

APPENDIX

# Visual Index – Quick Reference

For the convenience of the user, a copy of the Visual Index has been provided with direct links to connector and jumper configuration data.

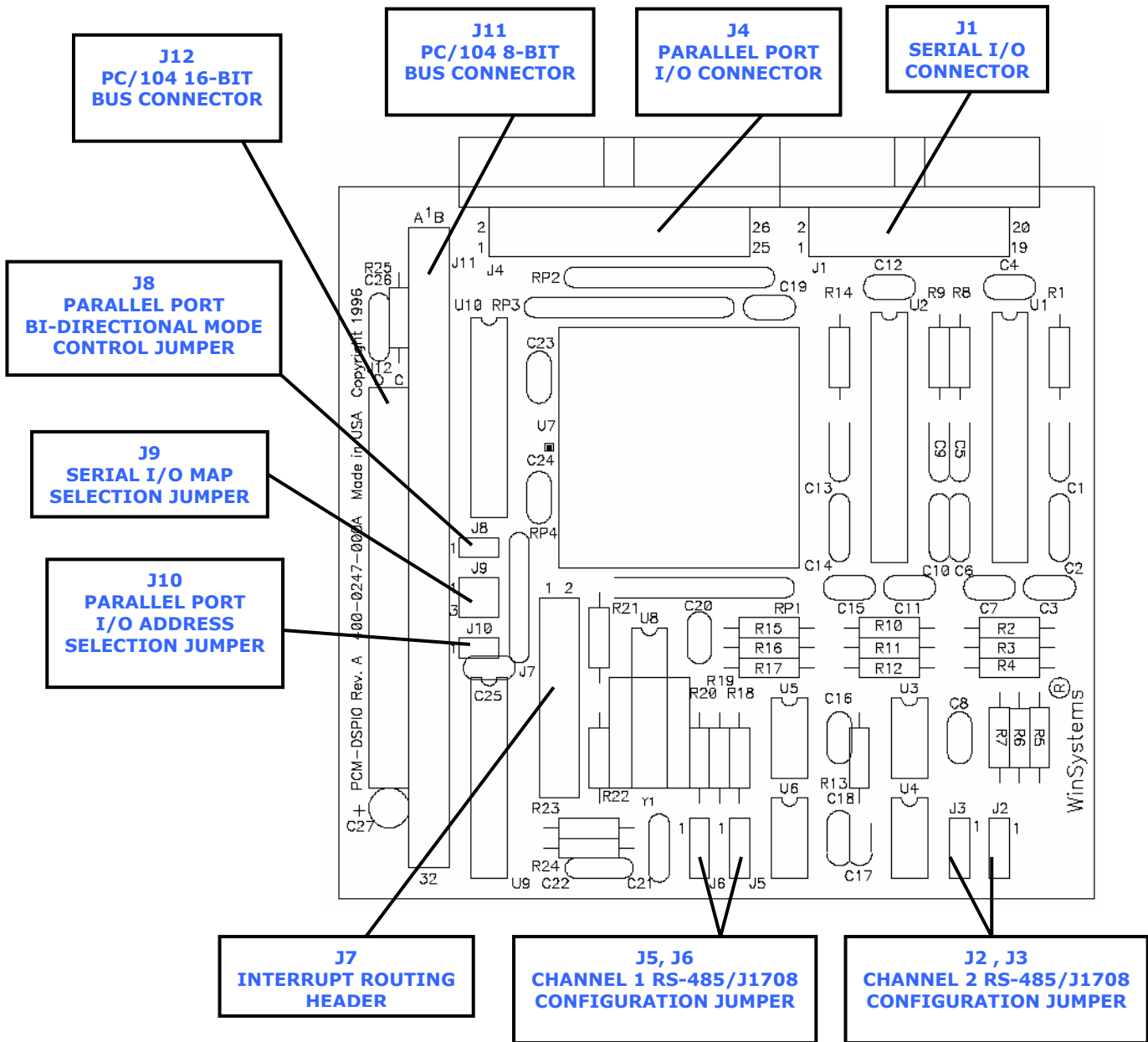

# 1

## GENERAL INFORMATION

### 1.1

#### FEATURES

- PC/104 compliant dual serial/parallel I/O module
- Two fully 16550 compatible async serial channels
- A fully compatible Centronics parallel port
- 16-byte serial transmit/receive FIFO
- Full RS-232 Modem control line support
- Programmable Baud rates from 50 to 115,200 bps
- Four Jumper selectable serial I/O maps
- Two jumper selectable Parallel port addresses
- Supports optional RS-422, RS-485, and SAE J1708 on both channels
- Dual mode bi-directional parallel printer port
- +5 Volt only operation
- -40° to +85° C operating temperature range

### 1.2

#### GENERAL DESCRIPTION

The PCM-DSPIO is a small low-cost, add-on module for PC/104 based systems that provides two PC compatible serial ports and a PC compatible parallel printer port. Both serial channels come standard supporting RS-232 including all standard Modem control lines. Either or both channels can optionally be configured for RS-422 or RS-485 interface levels. A factory configured option allows for support of SAE J1708 on both serial channels. The programmable 16-byte transmit and receive FIFOs allow for multiple channels of high speed serial I/O without excessive processor bottlenecks. The PC compatible parallel port can be used as a primary or secondary printer port or can be used for general purpose digital I/O with its bi-directional capability.

## **1.3 SPECIFICATIONS**

### **1.3.1 Electrical**

- Bus Interface : PC/104 8-Bit (optional 16-bit connector available for expanded interrupt capability)
- VCC : +5V +/-5% @ 90mA. typ. all channels RS-232  
120ma typ. all channels RS-422
- I/O Addressing : PLD Controlled I/O address uses 10-bit address. Each serial channel requires 8 consecutive I/O port addresses.  
Parallel port requires 4 consecutive I/O port addresses.

### **1.3.2 Mechanical**

- Dimensions : 3.8" X 3.8" X 0.5"
- PC Board : FR4 Epoxy Glass, with 2 signal layers with screened component legend, and plated through holes.
- Jumpers : 0.025" square posts on 0.10" centers
- Serial I/O Connector : 20 pin 0.10" grid RN type IDH-20-LP
- Parallel I/O Connector : 26 pin 0.10" grid RN type IDH-26-LP

### **1.3.3 Environmental**

- Operating Temperature : -40° to +85°C
- Non-Condensing Relative Humidity : 5% to 95%

# 2

# PCM-DSPIO TECHNICAL REFERENCE

## 2.1 Introduction

This section of the manual is intended to provide sufficient information regarding the configuration and usage of the PCM-DSPIO module. WinSystems maintains a Technical Support Group to help answer questions regarding configuration and programming of the board. For answers to questions not adequately addressed in this manual, contact Technical Support at (817) 274-7553 between 8AM and 5PM Central Time. Technical support may also be requested via FAX at (817) 548-1358. Appendix C contains the complete reprint of the Startech 16C552 datasheet and is provided to the programmer as a source of information for all UART registers and parallel port register details.

## 2.2 Serial I/O Address Selection

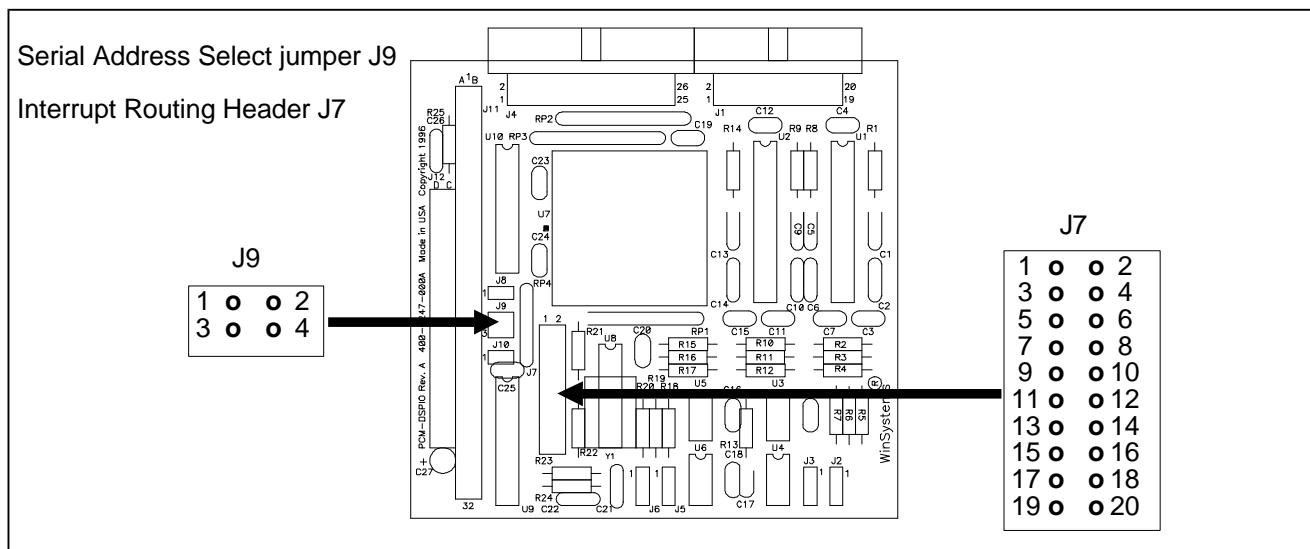

The PCM-DSPIO maps the two serial channels to any of 4 pairs of addresses as defined in the illustration below.



CH1 - 3F8H  
CH2 - 2F8H

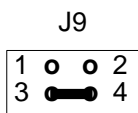

CH1 - 3E8H  
CH2 - 2E8H

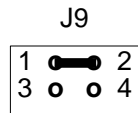

CH1 - 3A8H  
CH2 - 2A8H

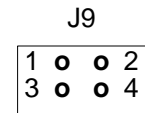

CH1 - 380H  
CH2 - 280H

## 2.3 Serial Interrupt Selection

Both serial channels can be programmed to generate interrupts on Transmitter empty, Receive character ready, or Line status changes. Each channel's interrupt output can be routed to an IRQ pin on the PC/104 bus via the jumper block at J7. Note that each channel is repeated throughout the jumper block several times allowing access to most any of the bus interrupts. Jumpers may be placed vertically or horizontally to route the serial interrupt to the bus. The illustration below shows the J7 header and its corresponding pin definitions.

J7		
CH1	1 ○ ○ 2	IRQ2
IRQ3	3 ○ ○ 4	CH2
CH1	5 ○ ○ 6	IRQ4
IRQ5	7 ○ ○ 8	CH2
CH1	9 ○ ○ 10	IRQ7
IRQ10	11 ○ ○ 12	CH2
CH1	13 ○ ○ 14	IRQ11
IRQ12	15 ○ ○ 16	CH2
CH1	17 ○ ○ 18	IRQ15
LPT	19 ○ ○ 20	CH2

## 2.4 RS-232 Mode Configuration

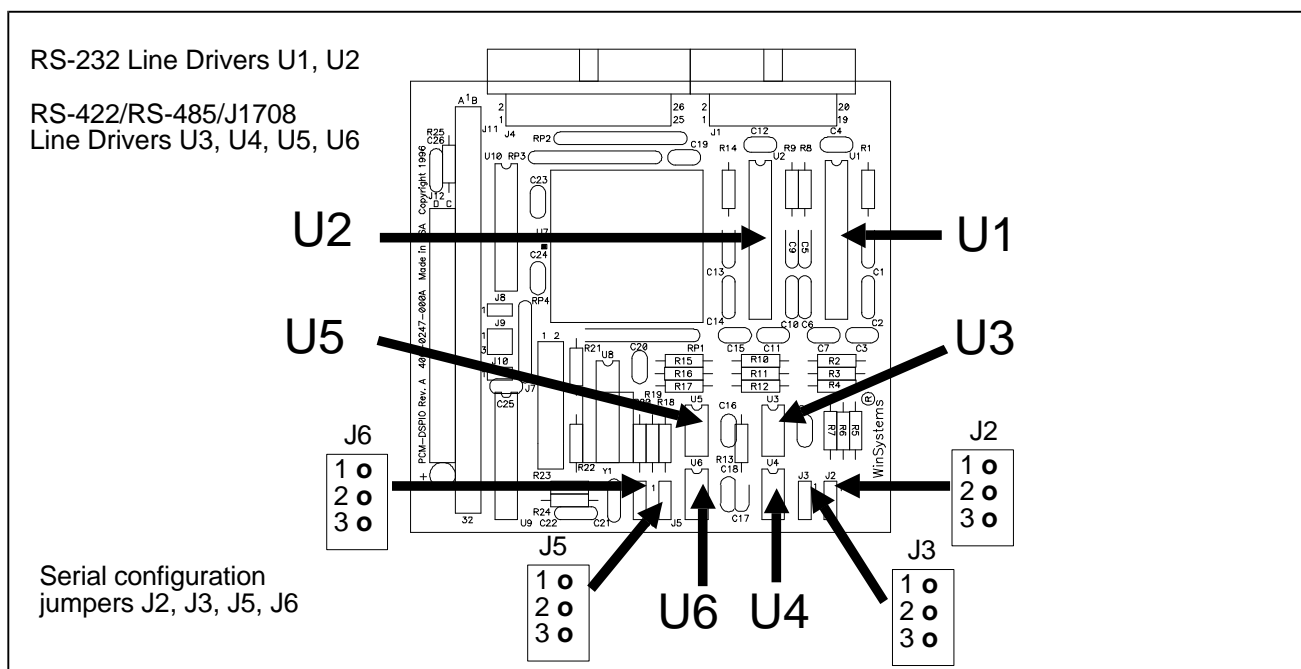

Full RS-232 signal levels are standard on both serial channels. The two serial channels are terminated at J1 and a dual DB9 cable is available from WinSystems under part number CBL-173-1. The following illustrations show the correct jumpering, driver IC installation, and DB9 I/O connector pin-out for RS-232 on each channel. Refer to Appendix D for pin definitions when not using the CBL-173-1 cable.



### 2.4.1 Channel 1 - RS-232

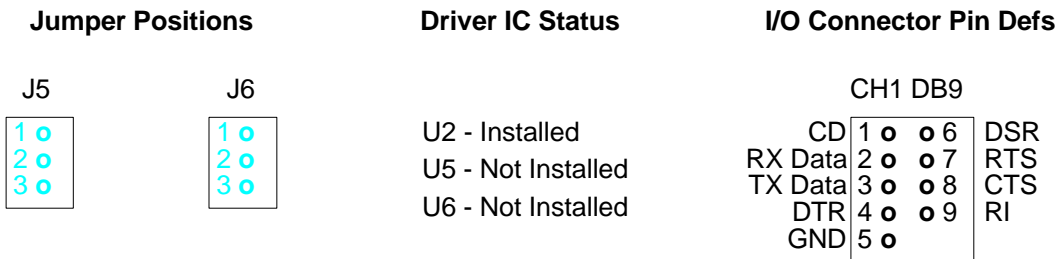

### 2.4.2 Channel 2 - RS-232

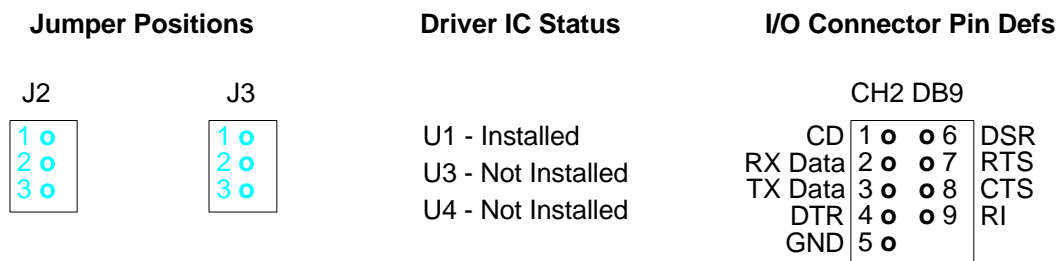

## 2.5 RS-422 Mode Configuration

RS-422 signal levels are supported on either or both serial channels with the installation of the optional "Chip Kit" part number CK-75176-2. This kit provides the driver ICs necessary for a single channel of RS-422. If two channels of RS-422 are required then two kit will be needed. RS-422 is a 4-wire point to point full-duplex interface allowing much longer runs than are possible with RS-232. The differential transmitter and receiver twisted-pairs offer a high degree of noise immunity. RS-422 usually requires that the lines be terminated at both ends. This termination can be accomplished either on the cable or by installing resistors on the board in locations reserved for them. The methodology in determining the correct resistor values is beyond the scope of this document but we recommend trial values of 100 Ohms in all three locations at the receiver end. The following illustrations show the correct jumpering, driver IC installation, DB-9 I/O connector pin-out, and termination resistor locations for each of the channels when used in RS-422 mode.

### 2.5.1 Channel 1 - RS-422

#### Jumper Positions



#### Driver IC Status

U2 - Not Installed  
 U5 - Installed  
 U6 - Installed

#### I/O Connector Pin Defs

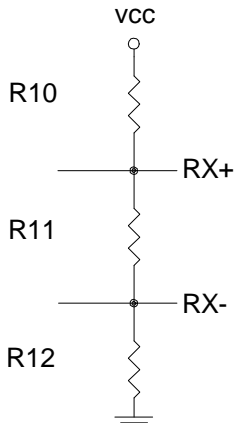
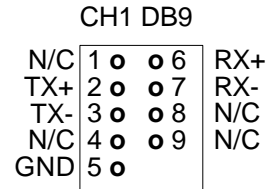

**RS-422 NOTE :** When used in RS-422 mode the transmitter must be enabled via software by setting the RTS bit in the Modem Control register (Bit 1).

### 2.5.2 Channel 2 - RS-422

#### Jumper Positions



#### Driver IC Status

U1 - Not Installed  
 U3 - Installed  
 U4 - Installed

#### I/O Connector Pin Defs

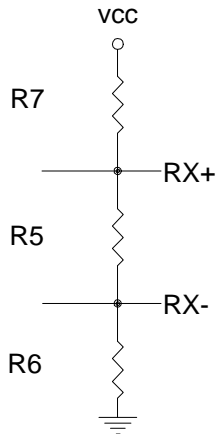
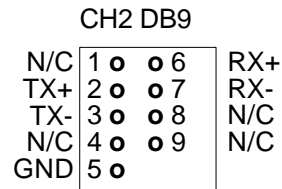



**RS-422 NOTE :** When used in RS-422 mode the transmitter must be enabled via software by setting the RTS bit in the Modem Control register (Bit 1).

## 2.6 RS-485 Mode Configuration

The RS-485 multi-drop interface is supported on both serial channels with the installation of the optional "Chip Kit", WinSystems part number CK-75176-2. A single kit is sufficient to configure both channels for RS-485. RS-485 is a 2 wire multi-drop interface where only one station at a time talks (transmits) while all others listen (receive). RS-485 usually requires that the line-pair be terminated at each end of the run. The required termination show the correct jumpering, driver IC installation, DB9 I/O connector pin-out, and termination resistor locations for each of the channels when used in the RS-485 mode.

### 2.6.1 Channel 1 - RS-485

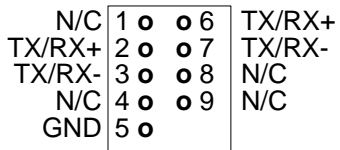
Jumper Positions		Driver IC Status	I/O Connector Pin Defs	
J5	J6	U2 - Not Installed	CH1 DB9	
		U5 - Installed		
		U6 - Not Installed		

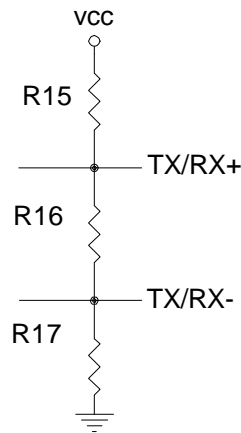

**RS-485 NOTE :** Because RS-485 uses a single twisted-pair, all transmitters are connected in parallel. Only one station may transmit, or have its transmitter enabled at a time. The transmitter Enable/Disable is controlled by Bit 1 in the Modem Control register (RTS). When set, the transmitter is enabled, when cleared (the normal state) the transmitter is disabled and the receiver is enabled. Note that it is necessary to allow some minimal settling time after enabling the transmitter before transmitting the first character. Likewise, following a transmission, it is necessary to be sure that all characters have been completely shifted out of the UART (Check bit 6 in the Line status register) before disabling the transmitter to avoid chopping off the last character.

**2.6.2** Channel 2 - RS-485

**Jumper Positions**

J2



J3

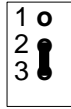

**Driver IC Status**

U1 - Not Installed  
 U3 - Installed  
 U4 - Not Installed

**I/O Connector Pin Defs**

CH2 DB9

N/C	1	6	TX/RX+
TX/RX+	2	7	TX/RX-
TX/RX-	3	8	N/C
N/C	4	9	N/C
GND	5		

**RS-485 NOTE :** Because RS-485 uses a single twisted-pair, all transmitters are connected in parallel. Only one station may transmit, or have its transmitter enabled at a time. The transmitter Enable/Disable is controlled by Bit 1 in the Modem Control register (RTS). When set, the transmitter is enabled, when cleared (the normal state) the transmitter is disabled and the receiver is enabled. Note that it is necessary to allow some minimal settling time after enabling the transmitter before transmitting the first character. Likewise, following a transmission, it is necessary to be sure that all characters have been completely shifted out of the UART (Check bit 6 in the Line status register) before disabling the transmitter to avoid chopping off the last character.

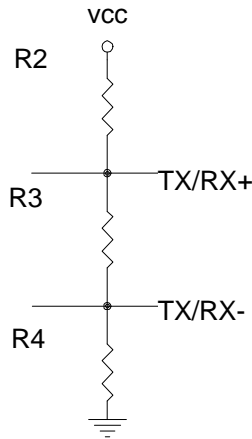

## 2.7 SAE J1708 Configuration

The Society of Automotive Engineers (SAE) J1708 interface is a variation of the RS-485 interface which is used for "Serial Data Communications between Microcomputer Systems in Heavy Duty Vehicle Applications". It is beyond the scope of this document to go into detail on the J1708 specification. The PCM-DSPIO must be factory configured for J1708 usage through the installation of a number of required termination and filtering components. The following illustrations show the correct jumpering, driver IC installation, DB9 I/O connector pin definitions, and termination network details for each of the channels when used in J1708 mode.

### 2.7.1 Channel 1 - SAE J1708

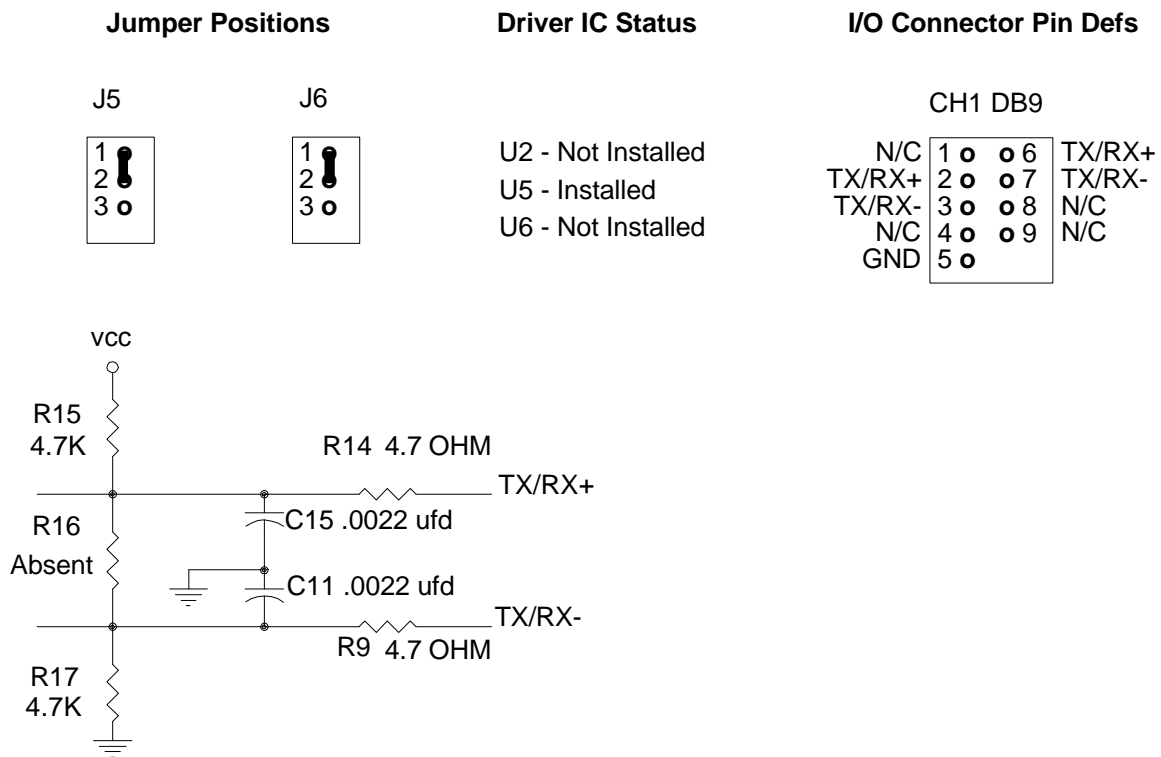

## 2.7.2 Channel 2 - SAE J1708

### Jumper Positions



### Driver IC Status

U1 - Not Installed  
 U3 - Installed  
 U4 - Not Installed

### I/O Connector Pin Defs

CH2 DB9		
N/C	1 ○ ○ 6	TX/RX+
TX/RX+	2 ○ ○ 7	TX/RX-
TX/RX-	3 ○ ○ 8	N/C
N/C	4 ○ ○ 9	N/C
GND	5 ○	

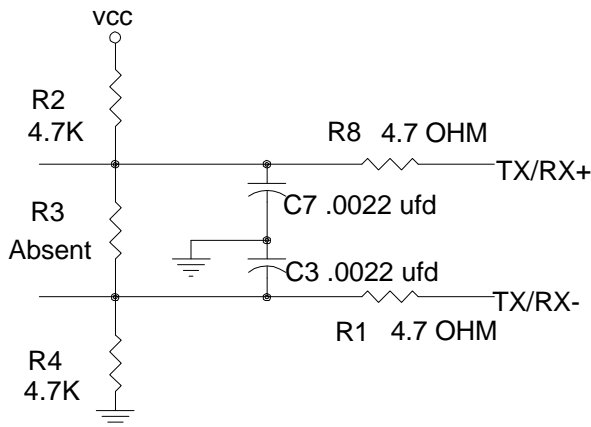

## 2.8 Parallel Port I/O Address Selection

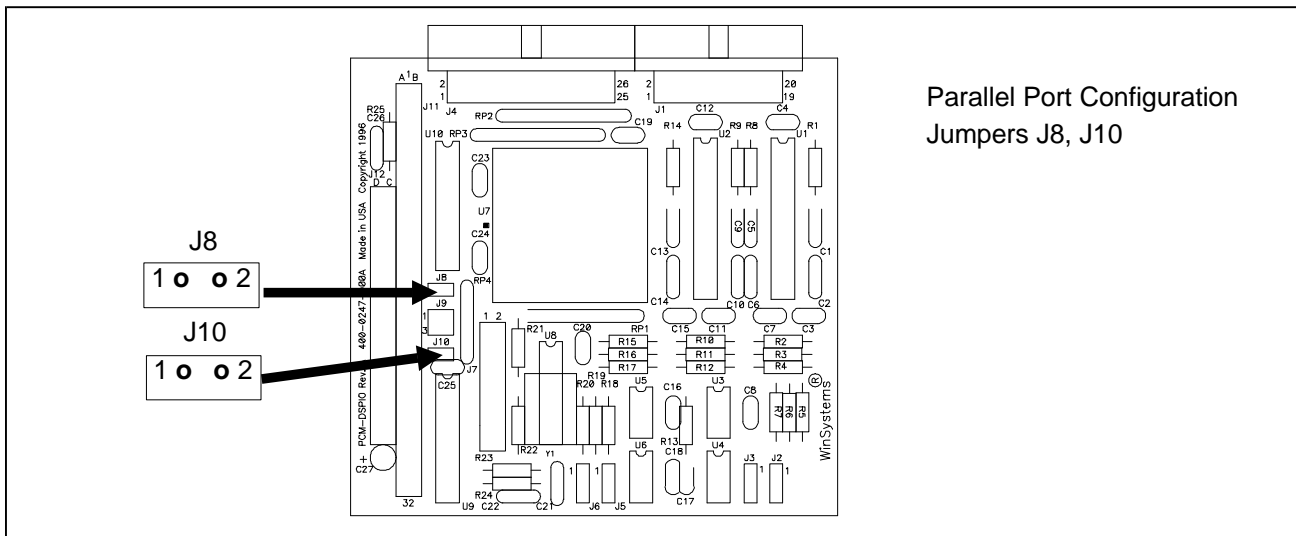

Parallel Port Configuration  
 Jumpers J8, J10

The parallel port on the PCM-DSPIO can be I/O mapped at either of 2 base addresses as determined by jumper block J10. The following illustration shows the J10 jumpering for each of the two supported addresses.

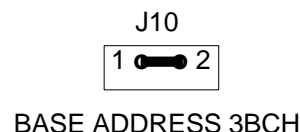
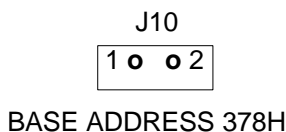

## 2.9 Parallel Port Direction Control

The parallel port on the PCM-DSPIO is capable of bi-directional data transfer. The jumper block at J8 defines the method(s) available to convert between input mode and output mode. The table below shows the relationship between the J8 jumper installation and the I/O selection modes available. For additional details on I/O direction control refer to the Startech 16C552 reprint in Appendix C.

Control Register Bit 5	J8 Jumper	I/O Select Register	Port Direction
X	ON	AA Hex	Input Mode
X	ON	55 Hex	Output Mode
0	OFF	X	Output Mode
1	OFF	X	Input Mode

## 2.10 Parallel Port Interrupt Routing

The parallel port on the PCM-DSPIO, like those on standard PC printer ports, is capable of generating an interrupt on printer acknowledge. This feature is not used by a PC BIOS and is rarely used by PC software. In the event this interrupt is desired, it may be routed to the bus using a jumper wire from pin 19 on J7 to the desired bus interrupt. The pin definitions for the J7 interrupt routing header are shown below :

J7

CH1	1	o	o	2	IRQ2
IRQ3	3	o	o	4	CH2
CH1	5	o	o	6	IRQ4
IRQ5	7	o	o	8	CH2
CH1	9	o	o	10	IRQ7
IRQ10	11	o	o	12	CH2
CH1	13	o	o	14	IRQ11
IRQ12	15	o	o	16	CH2
CH1	17	o	o	18	IRQ15
LPT	19	o	o	20	CH2

## 2.11 Parallel Port I/O Connector Pinout

The parallel port on the PCM-DSPIO terminates at connector J4. An interface cable WinSystems part number CBL-102-1 is available which connects to J4 and then presents the standard DB25 female connector to which PC printer cables may be attached. If using

the parallel port for custom I/O or for reference, the following illustration shows the pin definitions for J4.

J4			
/STB	1	2	/AFD
PD0	3	4	/ERROR
PD1	5	6	/INIT
PD2	7	8	/SLIN
PD3	9	10	GND
PD4	11	12	GND
PD5	13	14	GND
PD6	15	16	GND
PD7	17	18	GND
/ACK	19	20	GND
BUSY	21	22	GND
PE	23	24	GND
SLCT	25	26	N/C

## 2.12 PC/104 Bus Connectors

The PCM-DSPIO plugs onto the PC/104 bus using the connectors at J11 and J12 (PCM-DSPIO-16 only). The PC/104 bus pin definitions are shown here for reference.

J11			J12				
GND	B1	A1	IOCHK	GND	C0	D0	GND
RESET	B2	A2	SD7	SBHE	C1	D1	MEMCS16
+5V	B3	A3	SD6	LA23	C2	D2	IOCS16
IRQ2	B4	A4	SD5	LA22	C3	D3	IRQ10
-5V	B5	A5	SD4	LA21	C4	D4	IRQ11
DRQ2	B6	A6	SD3	LA20	C5	D5	IRQ12
-12V	B7	A7	SD2	LA19	C6	D6	IRQ15
OWS	B8	A8	SD1	LA18	C7	D7	IRQ14
+12V	B9	A9	SD0	LA17	C8	D8	DACK0
GND	B10	A10	IOCHRDY	MEMR	C9	D9	DRQ0
SMEMW	B11	A11	AEN	MEMW	C10	D10	DACK5
SMEMR	B12	A12	SA19	SD8	C11	D11	DRQ5
IOW	B13	A13	SA18	SD9	C12	D12	DACK6
IOR	B14	A14	SA17	SD10	C13	D13	DRQ6
DACK3	B15	A15	SA16	SD11	C14	D14	DACK7
DRQ3	B16	A16	SA15	SD12	C15	D15	DRQ7
DACK1	B17	A17	SA14	SD13	C16	D16	+5V
DRQ1	B18	A18	SA13	SD14	C17	D17	MASTER
DACK0	B19	A19	SA12	SD15	C18	D18	GND
CLK	B20	A20	SA11	KEY	C19	D19	GND
IRQ7	B21	A21	SA10				
IRQ6	B22	A22	SA9				
IRQ5	B23	A23	SA8				
IRQ4	B24	A24	SA7				
IRQ3	B25	A25	SA6				
DACK2	B26	A26	SA5				
T/C	B27	A27	SA4				
BALE	B28	A28	SA3				
+5V	B29	A29	SA2				
OSC	B30	A30	SA1				
GND	B31	A31	SA0				
GND	B32	A32	GND				



## 2.13 Connector/Jumper Summary

Connector/ Jumper	Purpose	Page Reference
J1	Serial I/O Connector	2-2
J2	Channel 2 RS-485/J1708 configuration jumper	2-3
J3	Channel 2 RS-486/J1708 configuration jumper	2-3
J4	Parallel Port I/O connector	2-9
J5	Channel 1 RS-485/J1708 configuration jumper	2-3
J6	Channel 1 RS-485/J1708 configuration jumper	2-3
J7	Interrupt routing header	2-2
J8	Parallel Port Bi-directional mode control jumper	2-9
J9	Serial I/O Map select jumper	2-1
J10	Parallel Port I/O address select jumper	2-8
J11	PC/104 8-bit Bus connector	2-10
J12	PC/104 16-bit Bus connector	2-10

# APPENDIX

## Startech 16C522 Datasheet Reprint

Printable datasheet in PDF format	<a href="#">DP83905_ ATLANTIC .pdf</a>
-----------------------------------	--

## Cables

Part Number	Description
<a href="#">CBL-101-3</a>	26-pin ribbon to 25-pin male "D" connector parallel adapter cable
<a href="#">CBL-173-1</a>	20-pin ribbon to two male 9-pin "D" connector adapter cable

## Software

Simple C routine that uses receive interrupt	<a href="#">8250INTA.ZIP</a>
--	------------------------------