

ITX-F-3800

Ultra Small Form Factor Single Board Computer with
Intel Atom[®] E3825 (Dual Core) CPU,
10/100/1000 Ethernet, Mini-PCIe, USB, and COM

Product Manual



Revision History

Document Version	Last Updated Date	Brief Description of Change
v1.0	7/16/18	Initial release
v1.1	12/2025	Updated Conformal Coating, added Warranty link, updated all links

Copyright and Trademarks

Copyright 2018, WinSystems, Inc.

No part of this document may be copied or reproduced in any form or by any means without the prior written consent of WinSystems, Inc. The information in the document is subject to change without notice. The information furnished by WinSystems, Inc. in this publication is believed to be accurate and reliable. However, WinSystems, Inc. makes no warranty, express, statutory, implied or by description, regarding the information set forth herein or regarding the freedom of the described devices from patent infringement. WinSystems, Inc. makes no warranty of merchantability or fitness for any purpose. WinSystems, Inc. assumes no responsibility for any errors that may appear in this document.

Trademark Acknowledgments

WinSystems is a registered trademark of WinSystems, Inc.

Intel is a registered trademark and Intel Atom is a trademark of Intel Corporation.

All other marks are the property of their respective companies.

Table of Contents

1	Before You Begin	5
1.1	Warnings	5
2	Introduction	5
3	Functionality	5
4	Features	6
5	General Operation	8
5.1	System Block Diagram	8
6	Specifications	9
7	Configuration	10
7.1	Component Layout	10
7.1.1	Top View	10
7.2	Watchdog Timer (WDT)	11
7.3	Real-time Clock/Calendar	11
7.4	Connectors	11
7.4.1	BATT - CMOS Battery Connector	11
7.4.2	AUDIO - Audio interface	12
7.4.3	COM1 - COM Interface	12
7.4.4	FPH - Front Panel Pin Header	14
7.4.5	VGA - Analog VGA Display	14
7.4.6	eDP1 - eDP Interface	15
7.4.7	DIO - Digital Input/Output	15
7.4.8	LAN1 - LAN 10/100/1000 Ethernet Interface	16
7.4.9	LED1 - Ethernet LED	17
7.4.10	TOUCH - Touchscreen COM Interface	17
7.4.11	I2C - I2C Bus Interface	19
7.4.12	PWR - DC Power Input	19
7.4.13	USB1-USB5 - USB Interface	20
7.4.14	MC1 - PCI Express Mini Card	21
7.4.15	M2SSD - PCI Express M.2 B Key Mini Card	22
7.4.16	Additional Information	23
7.5	Jumpers	23
7.5.1	JCMOS - CMOS Data Clear	23

7.5.2	JVL1 - eDP Panel Power Select	24
8	BIOS Functionality	24
8.1	General Information	24
8.2	Entering Setup	25
8.3	BIOS Setup Menu Navigation	25
8.4	BIOS Screens	25
8.4.1	Main Menu	25
8.4.2	Advanced Menu	27
8.4.3	Security Menu	29
8.4.4	Power Menu	30
8.4.5	Boot Menu	31
8.4.6	Exit Menu	32
8.5	Super I/O Settings	33
8.6	Glossary	34
8.7	Software Description	34
8.7.1	Software Design Specification: UEFI Operating System Support	34
8.7.2	Software Design Specification: Legacy Operating System Support	34
8.7.3	Software Design Specification: Boot Device Configuration	35
8.7.4	Software Design Specification: BIOS Update Mechanisms	35
8.7.5	Software Design Requirements: BIOS Components	35
8.8	BIOS Update with UEFI Shell	36
8.8.1	Scope	36
8.8.2	Process	36
9	Accessories and Cables	38
9.1	Package Contents	38
9.2	Accessory List	38
10	Software Drivers	39
A	Best Practices	40
B	Mechanical Drawings	43
C	Warranty Information	44

1. Before You Begin

Review the warnings in this section and the best practice recommendations (see “Best Practices” on page 40) when using and handling the WinSystems ITX-F-3800. Following these recommendations provides an optimal user experience and prevents damage. Read through this document and become familiar with the ITX-F-3800 before proceeding.



APPLYING CONFORMAL COATING AFTER PURCHASE WILL VOID YOUR WARRANTY. FAILING TO COMPLY WITH THESE BEST PRACTICES MAY DAMAGE THE ITX-F-3800 AND VOID YOUR WARRANTY.

1.1 Warnings

Only qualified personnel should configure and install the ITX-F-3800. While observing best practices, pay particular attention to the following:



Avoid Electrostatic Discharge (ESD)

Only handle the circuit board and other bare electronics when electrostatic discharge (ESD) protection is in place. Having a wrist strap and a fully grounded workstation is the minimum ESD protection required before the ESD seal on the product bag is broken.

2. Introduction

This manual provides configuration and usage information for the ITX-F-3800. If you still have questions, contact Technical Support at (817) 274-7553, Monday through Friday, between 8 AM and 5 PM Central Standard Time (CST).

Refer to the WinSystems website for other accessories (including cable drawings and pinouts) that can be used with your ITX-F-3800.

3. Functionality

WinSystems’ ITX-F-3800 series single board computers (SBCs) pack an impressive feature set into an ultra small form factor design. This SBC is based on the Intel E3800 processor family, which provides CPU and graphics performance. The ITX-F-3800 is a perfect choice for applications requiring low power and Intel performance in an ultra small form factor package with industrial connectors and I/O.

The integrated Intel Atom® (formerly Bay Trail-I) offers superb performance and product longevity. Available in an Intel E3825 1.33 GHz dual-core CPU, the integrated chipset and graphics engines provide the processing power and graphics capabilities for demanding embedded and IoT applications. The ITX-F-3800 includes 2 GB DDR3L SDRAM soldered down to the board with a data transfer rate of 1066 MHz.

Intel’s 7th generation (Gen 7) graphics and media encode/decode engine supports DirectX*11, OpenGL 3.0 (OGL 3.0), OpenCL 1.2 (OCL 1.2), OpenGLES 2.0, and multiple

displays. The graphics engine along with embedded DisplayPort (eDP) and on-board touch screen controller make the ITX-F-3800 a great choice for small human machine interface (HMI) applications.

Considering the small size of the ITX-F-3800, it is packed with I/O features often lacking from larger SBCs. It includes a 10/100/1000 Ethernet controller based on the Intel i211 family with wake-on-LAN and PXE capabilities, connectivity, and controlling network devices. Three USB 2.0 enhanced host ports and one USB 3.1 Gen 1 port provide additional functionality and expansion options. Also on board is one RS-232/422/485 multi-channel serial port. Expansion options for the ITX-F-3800 series include one full-size Mini Card for PCIe/USB/mSATA, and one M.2 (B key for SSD, type 2242).

The compact all-in-one ITX-F-3800 SBC is fully compatible with industry standards featuring technical enhancements for industrial applications and high reliability. It can run Microsoft Windows 10 variants including Windows 10 IoT Enterprise and Windows 10 IoT Core, as well as Linux, and real-time operating systems (RTOS). The ITX-F-3800 from WinSystems is a very compact, PC compatible single board computer which is a perfect fit for applications in UAV, energy, medical diagnostics, and industrial control.

4. Features

The ITX-F-3800 provides the following features:

Single Board Computer

- Intel Atom (formerly Bay Trail-I) E3800 series processor
- Dual Core E3825 1.33 GHz processor

Operating Systems (compatibility)

- Microsoft Windows 10 IoT Enterprise, Windows 10 IoT Core
- Linux
- Real-time operating systems (RTOS)

Memory

- Up to 2 GB DDR3L system RAM, data transfer rate of 1066 MHz

Graphics

- Fast graphics at high resolutions
- Intel Gen 7 HD graphics for Intel Atom processor
- Full-HD and 3D graphics acceleration

BIOS

- Insyde UEFI BIOS

Video Interfaces

- VGA
- Dual eDisplayPort

Ethernet

- One 10/100/1000 Mbps controller using Intel i211-AT

Storage

- One full-size PCIe Mini Card slot for mSATA
- One M.2 slot (B Key for SSD, type 2242)

Serial Interface

- One RS-232/422/485 multi-channel serial port

USB

- Three USB 2.0 ports
- One USB 3.1 Gen 1 port

Digital Input/Output

- Four digital inputs
- Four digital outputs

Bus Expansion

- One full PCIe Mini Card for PCIe/USB/mSATA slot
- One M.2 slot (B Key for SSD, type 2242)

Audio

- Line-out / Line-in / Mic-in / SPDIF-out

Power

- +5V DC

Industrial Operating Temperature

- -20 to +85°C (-4 to +185°F)

Form Factor

- Femto-ITX form factor 84 x 55 mm (3.3 x 2.2 inches)

Touch Function

- COM interface touchscreen controller, supports 4, 5, and 8 wire analog resistive touchscreen

Additional Features

- Performance for industrial IoT applications
- Connectivity and I/O for embedded systems
- Optimized for ultra small form factor designs
- Watchdog timer, 0~255 sec programmable

5. General Operation

5.1 System Block Diagram

The ITX-F-3800 ultra small single-board computer (SBC) provides performance for industrial IoT applications and rugged design for demanding environments with fast, high-resolution graphics, secure data, embedded connectivity, and expansion options. The following figure is a simplified system block diagram of the ITX-F-3800.

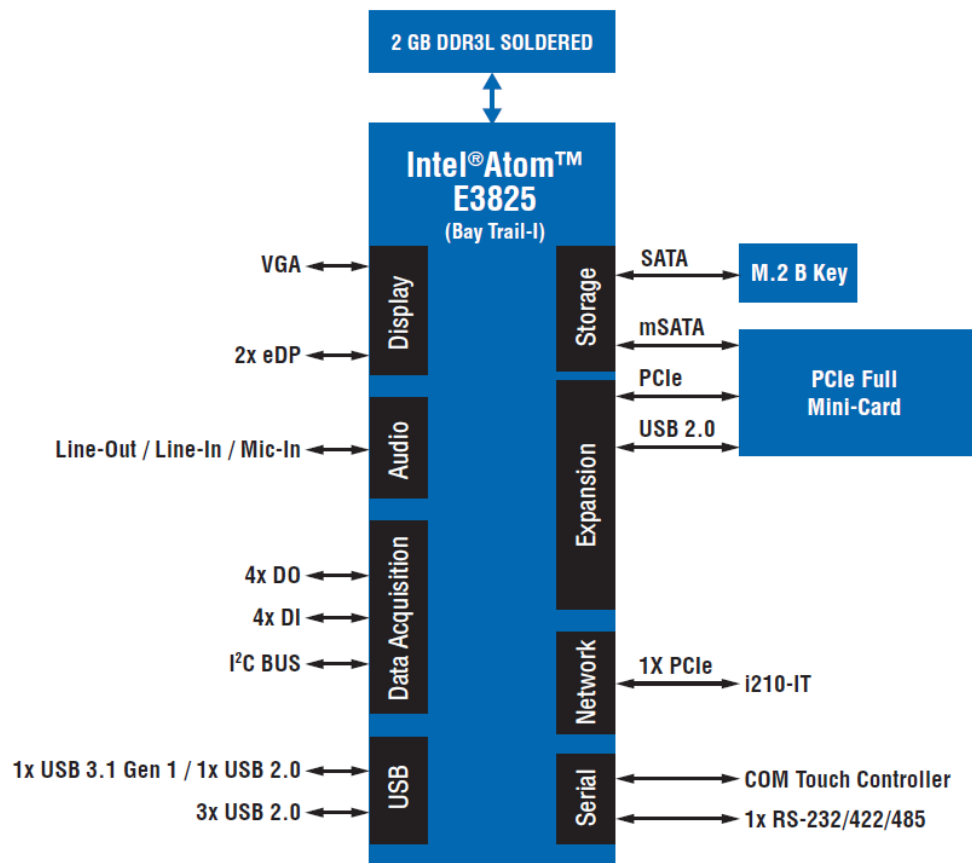

The ITX-F-3800 features the Intel Atom dual core system on chip (SOC). Its robust design, ultra small size, and extended operational temperature make it ideal for use in industrial IoT applications and embedded systems for industrial controls, transportation, Mil/COTS, and energy markets.

The soldered down memory provided enables up to 2 GB of DDR3L RAM. M.2 SSD and mSATA support are also provided.

The VGA and eDP display interfaces support simultaneous video output. There are three USB 2.0 ports and one USB 3.1 Gen 1 connector that supports an additional USB 2.0 port. There is one RS-232/422/485 multi-channel serial port.

There are four hardware digital inputs and four hardware digital outputs. The digital inputs have a 10 k Ω pull up resistor to +5V by default.

Other features include beep tones for error notification, and a watchdog timer supported RTC with optional battery back up.

Drivers are available from the WinSystems website.

6. Specifications

The ITX-F-3800 adheres to the following specifications and requirements.

Table 1: ITX-F-3800 specifications

Feature	Specification
Electrical	
V _{CC}	+5V DC
Models	ITX-F-3825-2-0
Processor	Dual core Intel Atom (formerly Bay Trail-I) E3800 series processor <ul style="list-style-type: none"> Dual core E3825 1.33 GHz processor
Mechanical	
Dimensions	Femto-ITX form factor 84 x 55 mm (3.3 x 2.2 inches)
Weight	102.52 g (3.62 oz.)
PCB thickness	0.063 in. (1.6 mm)
Environmental	
Temperature	-20 to +85°C (-4 to +185°F) ^a
Humidity (RH)	5% to 95% non-condensing
Mean time between failure (MTBF) ^b	50,000 (hrs)
RoHS compliant	Yes
Operating Systems	
Runs 64-bit Windows, Linux, and other x86-64-compatible operating systems.	

a. Requires airflow.

b. A MTBF measurement is based on a statistical sample and is not intended to predict any one specific unit's reliability; thus MTBF is not, and should not be construed as, a warranty measurement.

7. Configuration

This section describes the ITX-F-3800 components and configuration.

7.1 Component Layout

7.1.1 Top View

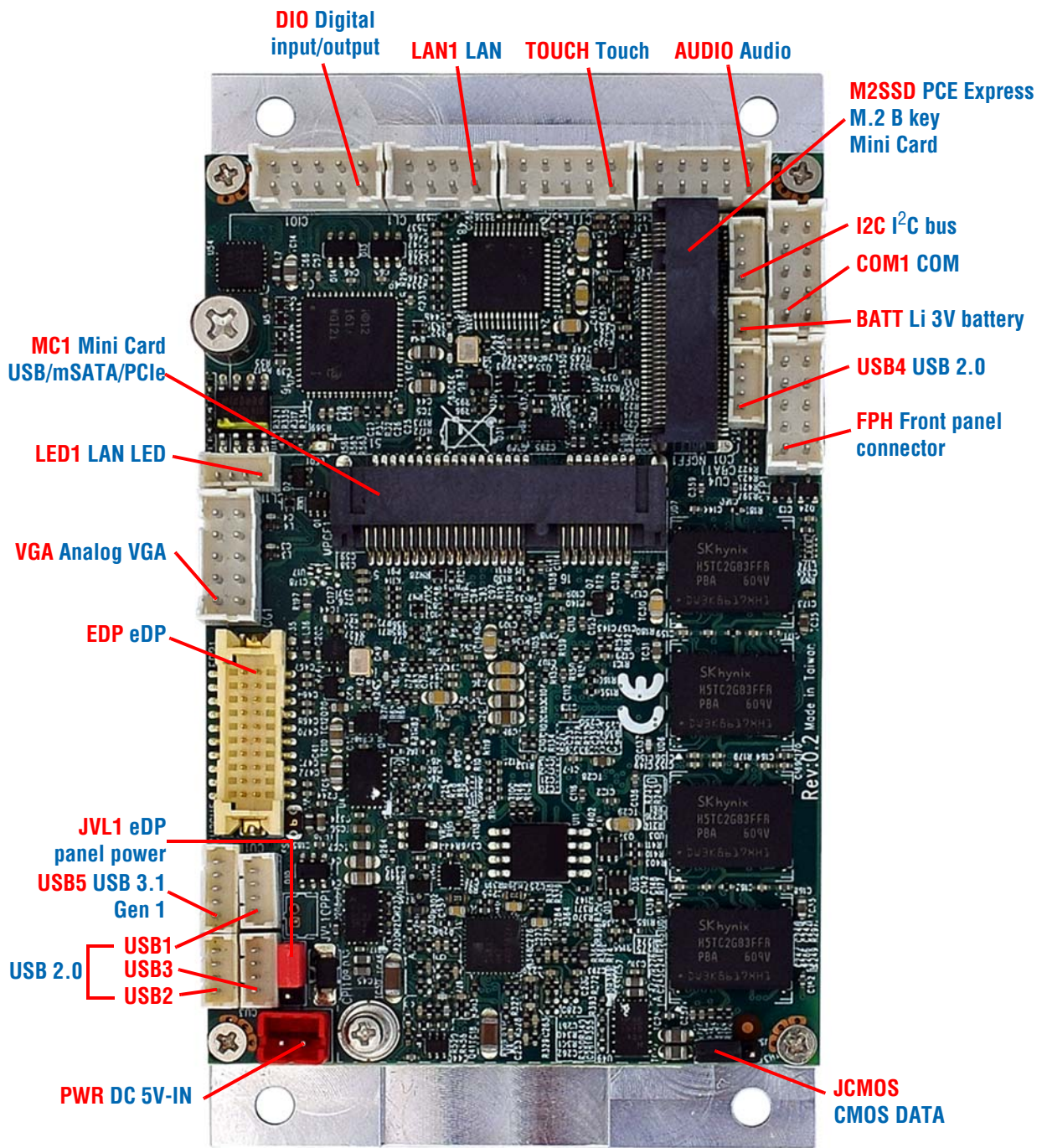

Table 2: Top view components

Item	Description	Reference
BATT	CMOS battery connector	page 11
AUDIO	Line-in/mic-out/line-out	page 12
COM1	COM port	page 12
FPH	Front panel header	page 14
VGA	Analog VGA	page 14
eDP1	eDP interface	page 15
DIO	Digital input/outputs	page 15
LAN	10/100/1000 Ethernet	page 16
TOUCH	Touch input	page 17
I2C	I ² C bus	page 19
PWR	DC Power input	page 19
USB1-USB5	USB interface	page 20
MC1	PCIe Mini Card express socket	page 21
M2SSD	PCIe M.2 B key Mini Card	page 22

7.2 Watchdog Timer (WDT)

The ITX-F-3800 features an advanced watchdog timer (WDT) to guard against software lockups; it resets the system if software does not pet the watchdog within the given time-out period. WinSystems supports the ITX-F-3800 WDT in the System Management tools for the ITX-F-3800. Ask your sales representative for details of this software package.

7.3 Real-time Clock/Calendar

A real-time clock is used as the AT-compatible clock/calendar. In addition to the time and date-keeping functions, the system configuration is kept in CMOS RAM contained within the clock section. A battery must be enabled for the real-time clock to retain time and date during a power down.

WinSystems has software available for manipulating the CMOS RTC from a high-level application.

7.4 Connectors

7.4.1 BATT - CMOS Battery Connector

BATT: Li 3V battery connector (1x2 pin 1.25 mm). Battery uses Li 3V / 40mAh (CR1220).

- The RTC consumes 2.7 uA when the power adapter is NOT connected.
- The RTC consumes 0.1 uA when the power adapter is connected.



Pin	Description
1	GND
2	+3V

Matching Connectors

- Molex 53047-0210

Cable Housing

- Molex 51021-0200

7.4.2 AUDIO - Audio interface

AUDIO: Line-out/line-in/mic-in/SPDIF-out connector (2x5 pin 2.0 mm)

Layout and Pin Reference

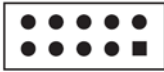

Pin	Description	Pin	Description
1	Line-out-R	2	MIC-IN
3	Line-in-R	4	GND
5	GND	6	SPDIF-out
7	Line-in-L	8	+5V
9	Line-out-L	10	MIC-IN

Matching Connectors

- JST B10B-PHDSS

Cable Housing

- JST PHDR-10VS

7.4.3 COM1 - COM Interface

COM1: 2x5 pin (2.0 mm) connector. RS232 (default) or RS422/485 from “Super I/O Settings” on page 33.

Layout and Pin Reference

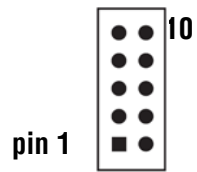

COM1 connector, RS232 mode

Pin	Description	Pin	Description
1	DCD	2	DSR
3	RXD	4	RTS
5	TXD	6	CTS
7	DTR	8	RI
9	GND		

COM1 connector, RS485 mode

Pin	Description	Pin	Description
1	RS485 Data+	2	NC
3	RS485 Data-	4	NC
5	NC	6	NC
7	NC	8	NC
9	GND		

COM1 wafer connector, RS422 mode

Pin	Description	Pin	Description
1	RS422 TX-	2	NC
3	RS422 TX+	4	NC
5	RS422 RX+	6	NC
7	RS422 RX-	8	NC
9	GND		

Matching Connectors

- JST B10B-PHDSS

Cable Housing

- JST PHDR-10VS

7.4.4 FPH - Front Panel Pin Header

FPH: Front panel connector 2x5 pin (2.0 mm)

Layout and Pin Reference

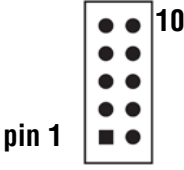

Pin	Description	Pin	Description
1	Power button pin	2	GND
3	Reset pin	4	GND
5	Power LED-	6	Power LED+
7	HDD LED-	8	HDD LED+
9	LAN LED-	10	LAN LED+

Matching Connectors

- JST B10B-PHDSS

Cable Housing

- JST PHDR-10VS

7.4.5 VGA - Analog VGA Display

VGA: Analog VGA connector (2x5 pin, 2.0 mm)

Layout and Pin Reference

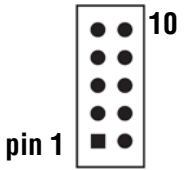

Pin	Description	Pin	Description
1	BLUE	2	GND
3	GND	4	DDC CLOCK
5	GREEN	6	V-SYNC
7	GND	8	H-SYNC
9	RED	10	DDC DATA

Matching Connectors

- JST B10B-PHDSS

Cable Housing

- JST PHDR-10VS

7.4.6 eDP1 - eDP Interface

eDP1: eDP connector (2x10 pin, 1.25 mm)

Layout and Pin Reference

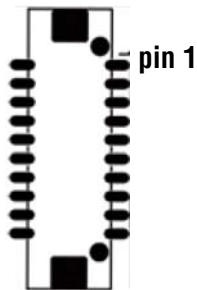
eDP1	Pin	Description	Pin	Description
	1	Lane-0-DATA-	2	+12V or +5V
	3	Lane-0-DATA+	4	+12V or +5V
	5	Lane-1-DATA-	6	GND
	7	Lane-1-DATA+	8	GND
	9	Backlight enable	10	GND
	11	PWM dimming for eDP	12	GND
	13	I ² C data	14	+LCD (5V or 3.3V)
	15	I ² C clock	16	+LCD (5V or 3.3V)
	17	eDP Aux+	18	+LCD (5V or 3.3V)
	19	eDP Aux-	20	GND
Notes: 1. The eDP interface supports 2 lanes. 2. JVL1: eDP panel +5V/+3.3V (default) voltage select. 3. eDP1 PIN 9 for panel backlight enable. +5V level. 4. eDP1 PIN 11 for panel backlight dimming control. 5. eDP1 pins 2 and 4 backlight power default set +5V.				

Matching Connectors

- Hirose DF13-20DP-1.25V

Cable Housing

- Hirose DF13-20DS-1.25C

7.4.7 DIO - Digital Input/Output

DIO: Digital input/output 0-3 connector (2x5 pin, 2.0 mm)

Layout and Pin Reference

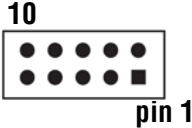
			
Pin	Description	Pin	Description
1	DI-0	2	DO-3
3	DI-1	4	DO-2
5	DI-2	6	DO-1
7	DI-3	8	DO-0
9	GND	10	+5V
Notes: 1. By default, there is a 10k ohm pull up resistor to +5V. 2. Circuit must be isolated to control external devices. 3. F75111N-1 I2C bus address 0x9c			

Matching Connectors

- JST B10B-PHDSS

Cable Housing

- JST PHDR-10VS

7.4.8 LAN1 - LAN 10/100/1000 Ethernet Interface

Layout and Pin Reference

LAN1: Ethernet port 2x4 pin (2.0 mm) connector

			
Pin	Description	Pin	Description
1	TR0-/TX-	5	TR1-/RX+
2	TR0+/TX+	6	TR2-/NC-
3	TR2+/NC	7	TR3-/NC
4	TR1+/RX-	8	TR3+/NC

Matching Connectors

- JST B8B-PHDSS

Cable Housing

- JST PHDR-08VS

7.4.9 LED1 - Ethernet LED

Layout and Pin Reference

LED1: LAN1 LED indicator connector (1x4 pin, 1.25 mm)



Pin	Description
1	VCC
2	Speed 10M
3	Speed 100M
4	Speed 1000M

RJ45 LAN connector-LED define

Speed		10 Mbps			100 Mbps			1000 Mbps		
Indicate	Side	Back		Front	Back		Front	Back		Front
	LED	Link	ACT	ACT	Link	ACT	ACT	Link	ACT	ACT
LAN light		Orange	Orange	Orange	Green	Orange	Orange	Red	Orange	Orange

Matching Connectors

- Molex 53047-0410

Cable Housing

- Molex 51021-0400

7.4.10 TOUCH - Touchscreen COM Interface

TOUCH: Touch connector (2x5 pin, 2.0 mm)

Layout and Pin Reference

10



pin 1

8-wire type pin define

Pin	Description	Pin	Description
1	Bottom	2	Bottom sense
3	Top sense	4	Top
5	Right	6	Right sense
7	Left	8	Left sense
9	GND	10	NC

Note: To configure for 8-wire touch setup, short pins 3 and 4 together.

4-wire type pin define

Pin	Description	Pin	Description
1	Bottom	2	N/A
3	N/A	4	Top
5	Right	6	N/A
7	Left	8	N/A
9	GND	10	NC

Note: To configure for 4-wire touch setup, short pins 3 and 4 together.

5-wire type pin define

Pin	Description	Pin	Description
1	UR(H)	2	N/A
3	Sense	4	UL(Y)
5	LR(X)	6	N/A
7	LL(L)	8	N/A
9	GND	10	NC

Matching Connectors

- JST B10B-PHDSS

Cable Housing

- JST PHDR-10VS

7.4.11 I2C - I2C Bus Interface

I2C: I²C bus connector (1x4 pin, 1.25 mm)

Layout and Pin Reference

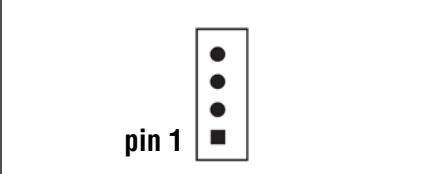

Pin	Description
1	+3.3V
2	GND
3	I ² C clock
4	I ² C data

Matching Connectors

- Molex 53047-0410

Cable Housing

- Molex 51021-0400

7.4.12 PWR - DC Power Input

Layout and Pin Reference

PWR: DC-IN (red) connector (1x2 pin, 2.0 mm)

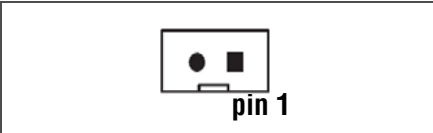

Pin	Description
2	DC-IN (5V)
1	GND

Matching Connectors

- JST B2B-PH-KL

Cable Housing

- JST PHR-2

7.4.13 USB1-USB5 - USB Interface

Layout and Pin Reference

USB1/USB2/USB3/USB4: USB 2.0 connector (1x4 pin, 1.25 mm)

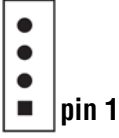
	
Pin	Description
1	+5V
2	DATA-
3	DATA+
4	GND
Note: USB4 signals share with the Mini Card (MC1).	

USB5: USB 3.1 Gen 1 connector (1x5 pin 1.25 mm)

NOTE USB1 must be used with USB5 to utilize USB 3.1 Gen 1.

	
Pin	Description
1	Data TX +
2	Data TX -
3	GND
4	Data RX +
5	Data RX -

Matching Connectors

- USB1-USB4: Molex 53047-0410
- USB5: Molex 53047-0510

Cable Housing

- USB1-USB4: Molex 51021-0400
- USB5: Molex 51021-0500

7.4.14 MC1 - PCI Express Mini Card

MC1: Supports mSATA, USB, and PCIe x 1 interface (Mini Card socket 52 pin)

Layout and Pin Reference

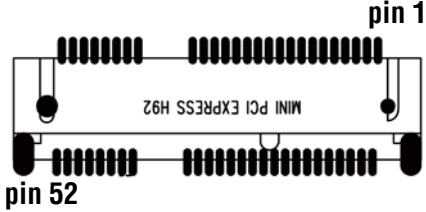
Pin	Description	Pin	Description
			
1	NC	2	+3.3V
3	NC	4	GND
5	NC	6	+1.5V
7	NC	8	NC
9	GND	10	NC
11	PCIe-CLK-	12	NC
13	PCIe-CLK+	14	NC
15	GND	16	NC
KEY			
17	NC	18	GND
19	NC	20	NC
21	GND	22	Reset
23	PCIe-RX-/mSATA-RX+	24	+3.3V
25	PCIe-RX+/mSATA-RX-	26	GND
27	GND	28	+1.5V
29	GND	30	SMB-CLK
31	PCIe-TX-/mSATA-TX-	32	SMB-DATA
33	PCIe-TX+/mSATA-TX+	34	GND
35	GND	36	USB-DATA-
37	GND	38	USB-DATA+
39	+3.3V	40	GND
41	+3.3V	42	NC
43	GND	44	NC
45	NC	46	NC
47	NC	48	+1.5V
49	NC	50	GND
51	mSATA/PCIe detect	52	+3.3V
Note: The MPCIE1 will autodetect mSATA/PCIe interface.			

7.4.15 M2SSD - PCI Express M.2 B Key Mini Card

M2SSD: Supports SATA-based SSD interface (Mini Card socket 75 pin)

Layout and Pin Reference

Pin	Description	Pin	Description
1	GND	2	+3.3V
3	GND	4	+3.3V
5	NC	6	NC
7	NC	8	NC
9	NC	10	NC
11	NC		
B KEY			
		20	NC
21	GND	22	NC
23	NC	24	NC
25	NC	26	NC
27	GND	28	NC
29	NC	30	NC
31	NC	32	NC
33	GND	34	NC
35	NC	36	DEVSLP
37	NC	38	NC
39	GND	40	NC
41	mSATA-RX+	42	NC
43	mSATA-RX-	44	NC
45	GND	46	NC
47	mSATA-TX-	48	NC
49	mSATA-TX+	50	NC
51	GND	52	NC
53	NC	54	NC
55	NC	56	NC
57	GND	58	NC
59	NC	60	NC
61	NC	62	NC
63	NC	64	NC
65	NC	66	NC
67	NC	68	NC
69	GND	70	+3.3V

Pin	Description	Pin	Description
71	GND	72	+3.3V
73	GND	74	+3.3V
75	GND		

7.4.16 Additional Information

To install a mini PCIe/mSATA into MC1 or M.2 B Key Mini Card into M2SSD:

1. Insert the mini PCIe/mSATA or M.2 B Key Mini Card.

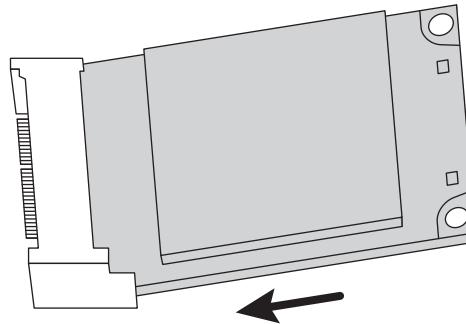

2. Push the free end of the card toward the circuit board and then secure it with either two (2 mm) screws for PCIe/mSATA card (WinSystems P/N G527-0000-400) or one (3 mm screw) for M.2 B Key Mini Card (WinSystems P/N 527-000A-303).

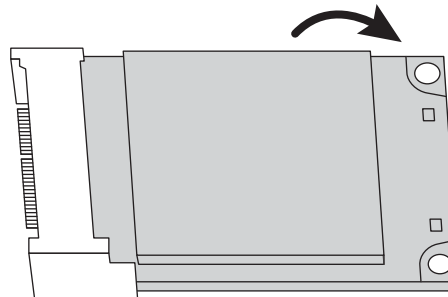

7.5 Jumpers

7.5.1 JCMOS - CMOS Data Clear

Jumpers can be used to reset the BIOS CMOS settings to the factory default. Enable/disable the clear CMOS function hardware circuit, by placing or removing the jumper from JCMOS as needed.

To reset the BIOS CMOS configuration to the factory default settings:

1. Remove power from the ITX-F-3800.

2. Find JCMOS.
3. Remove jumpers from pins 1-2.
4. Install jumpers on pins 2-3 and wait five seconds.
5. Replace jumpers back on pins 1-2.

NOTE Do not clear the CMOS except in these circumstances: 1) Troubleshooting; 2) Forgotten password; 3) You fail over-clocking system.

Layout and Pin Reference

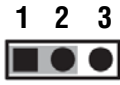
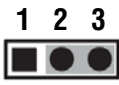
 *Normal	 Clear
Pin	Description
*1-2	Normal set
2-3	CMOS data clear

7.5.2 JVL1 - eDP Panel Power Select

Select the appropriate VCC setting using this jumper.

Layout and Pin Reference

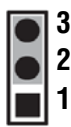
 +5V	 *+3.3V
Pin	Description
1-2	+5V
*2-3	+3.3V

8. BIOS Functionality

8.1 General Information

The ITX-F-3800 includes a UEFI BIOS from Insyde stored in Flash ROM. Access setup information through the BIOS setup utility to modify basic system configuration. The configuration is stored in CMOS RAM (it is retained during power off). When power is applied to the system, the ITX-F-3800 communicates with peripheral devices and checks hardware resources against the configuration information stored in the CMOS memory. If during startup an error is detected or the CMOS parameters need to be initially defined, the diagnostic program prompts the user to enter the SETUP program. Some errors are significant enough to cause the startup to fail.

8.2 Entering Setup

To enter setup, apply power to the computer and then press **Del**. You must press the **Del** key when either the splash screen is displayed (during the system power-on self test, POST) or when the **Press Del for Setup message** is displayed. It may take a few seconds before the main setup menu screen is displayed.

Press **Del** to enter the setup.

If the message disappears before responding and you still wish to enter Setup, restart the system by pressing the **RESET** button. It can be also restarted by pressing the **Ctrl**, **Alt**, and **Delete** keys on the keyboard simultaneously.

Press **F1** to run general help or resume.

The BIOS setup program provides a General Help screen. The menu can be easily called up from any menu by pressing **F1**. The Help screen lists all the possible keys to use and the selections for the highlighted item. Press **Esc** to exit the Help screen.

8.3 BIOS Setup Menu Navigation

In the BIOS Setup, use the following keys to navigate the menu options.

Key	Description
Left and right arrows	Select the screen
Up and down arrows	In the main menu, select an option to confirm or to modify.
Enter	Confirm selection.
+ and .	Modify the BIOS parameters for the active option.
F1	General help.
F2	Previous value.
F3	Optimized defaults.
F4	Save and reset.
Esc	Quit the BIOS setup.

8.4 BIOS Screens

The following BIOS screens contain the options and sample settings for the ITX-F-3800.

Your actual configuration may differ from the screens shown here.

NOTE Use care when modifying BIOS settings.

8.4.1 Main Menu

The Main page of the BIOS displays general information related to the current BIOS build, including the BIOS revision, the build date and time, and processor type.

The Main BIOS page also contains information related to the amount and configuration of the system RAM (the type of RAM used in the design).

InsydeH20 Setup Utility		Rev. 5.0
Main	Advanced	Security Power Boot Exit
BIOS Version	ITX-F-3800	
Build Date	05/17/2016	
Build Time	17:46:29	
Processor Type	Intel(R) Atom(TM) CPU E3825 @ 1.33GHz	
System Memory Speed	1066 MHz	
Cache RAM	1024 KB	
Total Memory	2048 MB	
System Time	[00:00:00]	
System Date	[01/01/2015]	
F1 Help	↑↓ Select	F5/F6 Change Values F9 Setup Defaults
Esc Exit	← Select Menu	Enter Select ► SubMenu F10 Save and Exit

- **System Information.** System Information parameters provide information and vary with BIOS version and the specific modules used. The typical format of the information is provided instead of the actual default setting or value.
 - BIOS Version, value format: yymmdd
 - BIOS Build Date, value format mm/dd/yyyy
 - BIOS Build Time, value format hh/mm/ss
 - Processor Type, value Intel(R) Atom(TM) CPU E3800 series
 - System Memory Speed, value 1066 MHz or 1333 MHz
 - L2 Cache RAM, value 2048 KB
 - Total Memory, value up to 4096 MB
- **System Time.** Displays the current time in HH/MM/SS format. To set or change the time, highlight the row using the up/down arrow keys, then highlight the hour, minute, or second by pressing the **Enter** key until the desired value is highlighted with a square block. Use the +/- keys to change the highlighted value.
- **System Date.** Displays the current date in MM/DD/YYYY format. To set or change the date, highlight the row using the up/down arrow keys, then highlight the month, day, or year by pressing the **Enter** key until the desired value is highlighted with a square block. Use the +/- keys to change the highlighted value, or enter the time using the number keys

8.4.2 Advanced Menu

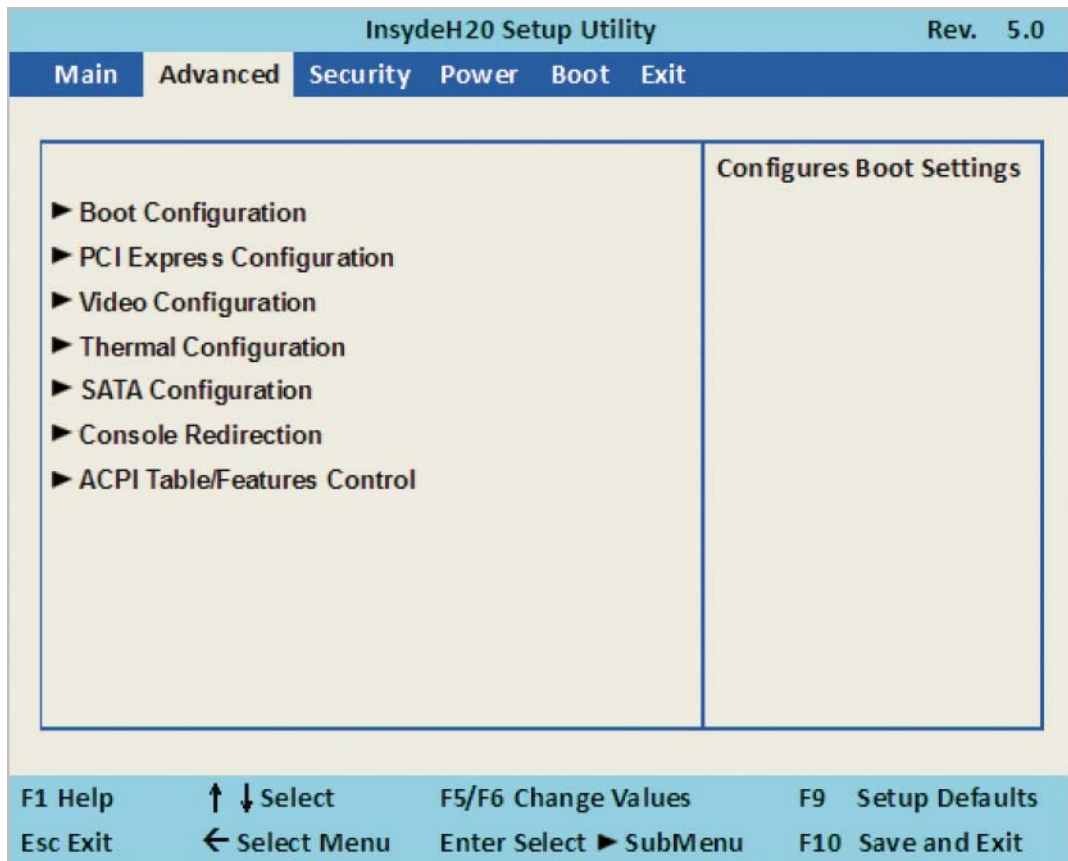

Boot Configuration

- Select power-on state for **Numlock**. Options are On (default), Off.

PCI Express Configuration

- Control the **PCI Express Root Port** for ports 1, 2, 3, and 4. Options are Enabled (default), Disabled.
- Select **PCI Express Port Speed**. Options are Gen1 (default), Gen2.
- Select **PCIE TXE ROM** support. Options are Disabled (default), Enabled.

Video Configuration

- **Configure CRT as**. Options are CRT (default), Default.
- **Configure eDP as**. Enable or disable eDP function. Options are Enabled (default), Disabled.
- **Aperture Size**. Options are 128MB, 256MB (default), 512MB.
- **IGD - DVMT Pre-Allocated**. Use this item to select DVMT 5.0 total graphics memory size used by the internal graphics device. Options are 64 (default), 128, 256, 512MB.

- **IGD - DVMT Total Gfx Mem.** Use this item to select DVMT 5.0 pre-allocated (fixed) graphics memory size used by the internal graphics device. Options are 128M, 256M (default), MAX.

Thermal Configuration

This value controls the temperature of the ACPI critical trip point, the point where the OS shuts down the system. The default value for the critical trip point is 110°C. The CPU frequency is throttled when it reaches its passive trip point. The default value for the passive trip point is 105°C.

SATA Configuration

- **SATA Controller.** Use this item to Enable or Disable SATA Device. Options are Enabled (default) or Disabled.
- **Chipset SATA Mode.** Determine how SATA controller(s) operate. Options are IDE Mode (default), AHCI Mode.
- **SATA Speed.** Indicates the maximum speed the SATA controller can support. Options are Gen1, Gen2 (default).
 - **IDE Mode. Legacy IDE or Native IDE MODE.** Options are Legacy IDE or Native IDE (default)
 - **SATA Port 0 Connected to an ODD.** Use this item to enable or disable SATA Port0 ODD function Options are Enabled (default) or Disable.
 - **SATA Port 1 Connected to an ODD.** Use this item to enable or disable SATA Port1 ODD function. Options are Enabled (default) or Disable.

Console Redirection Setup

- **Console Serial Redirect.** Use this item to enable or disable Console Redirection. Options are Enabled, Disabled (default).
- **Text Mode Resolution.** Options are Force 80x25, Force 80x24 (DEL FIRST ROW), Force 80x24 (DEL LAST ROW) (default).
- **Baud Rate.** Options are 115200 (default), 57600, 38400, 19200, 9600, 4800, 2400, 1200.
- **Data Bits.** Options are 8 Bits (default), 7 Bits.
- **Parity.** Options are None (default), Even, Odd.
- **Stop Bits.** Options are 1 Bit (default), 2 Bits.
- **Flow Control.** Options are None (default), RTS/CTS, XON/XOFF.

ACPI Table/Features Control

DSDT - ACPI S3. Select the ACPI sleep state the system enters when the SUSPEND button is pressed. Options are DSDT - ACPI S3 (Suspend to RAM), Enabled, Disabled (default).

8.4.3 Security Menu

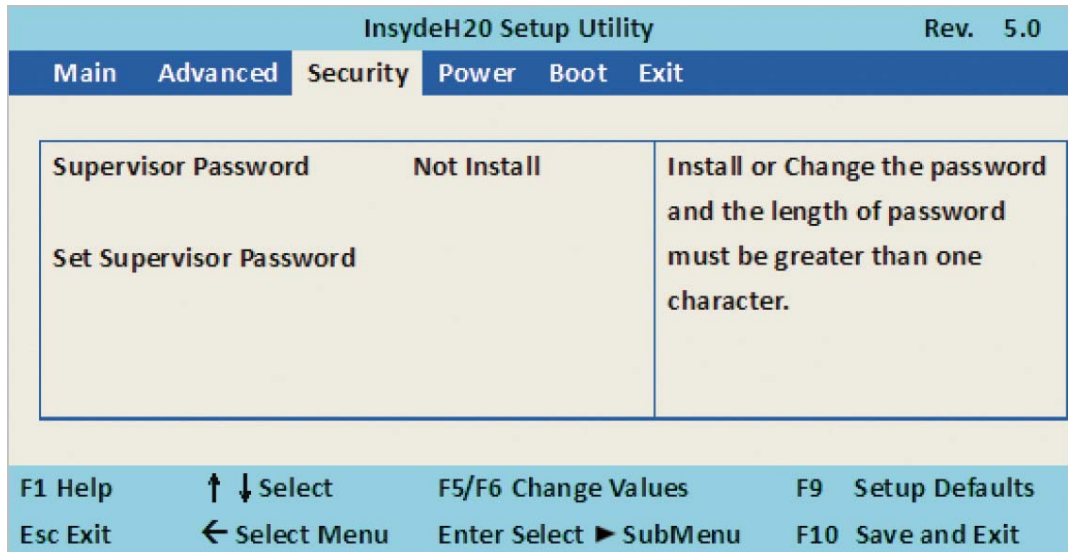

Supervisor Password

To set up a supervisor password:

1. Select **Set Supervisor Password**.
A Create New Password dialog opens.
2. Type your desired password using no fewer than 3 characters and no more than 10 characters.
3. Press **Enter**.

8.4.4 Power Menu

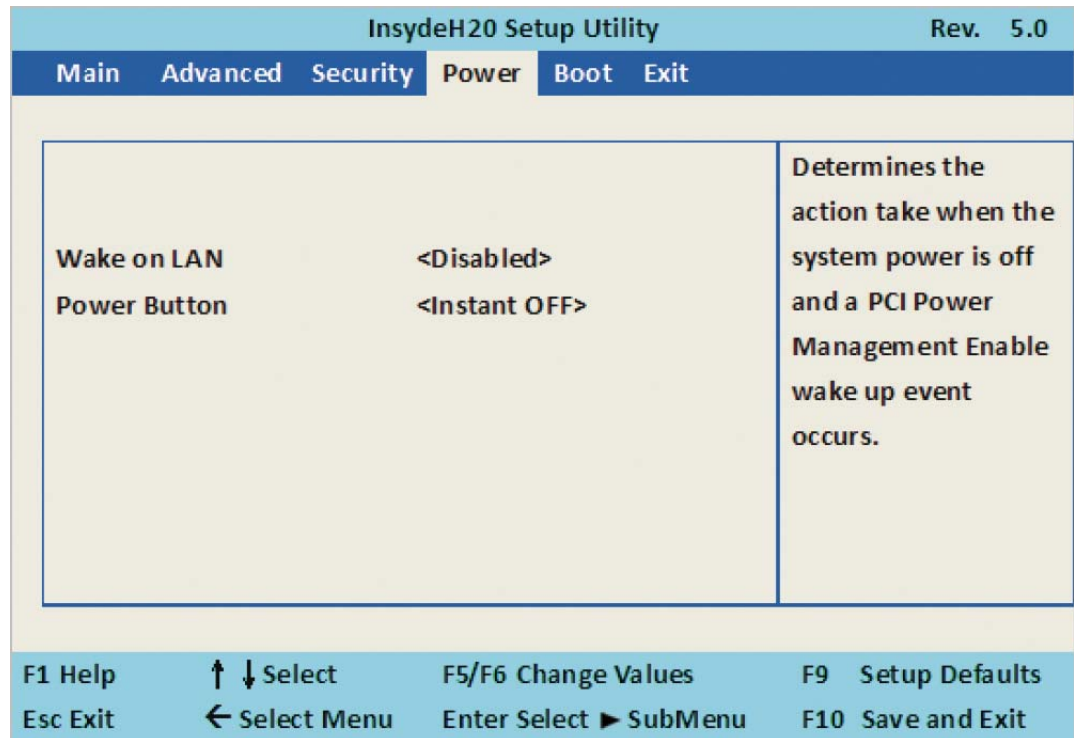

- **Wake on LAN.** Determines the action taken when the system power is off and the PCI power management Enable wake up event occurs. Options are Enabled, Disabled (default).
- **Power Button.** Options are:
 - Instant OFF: The system automatically turns off when the power button is pressed.
 - Delay 4 sec: The system automatically turns off after 4 seconds when the power button is pressed.

8.4.5 Boot Menu

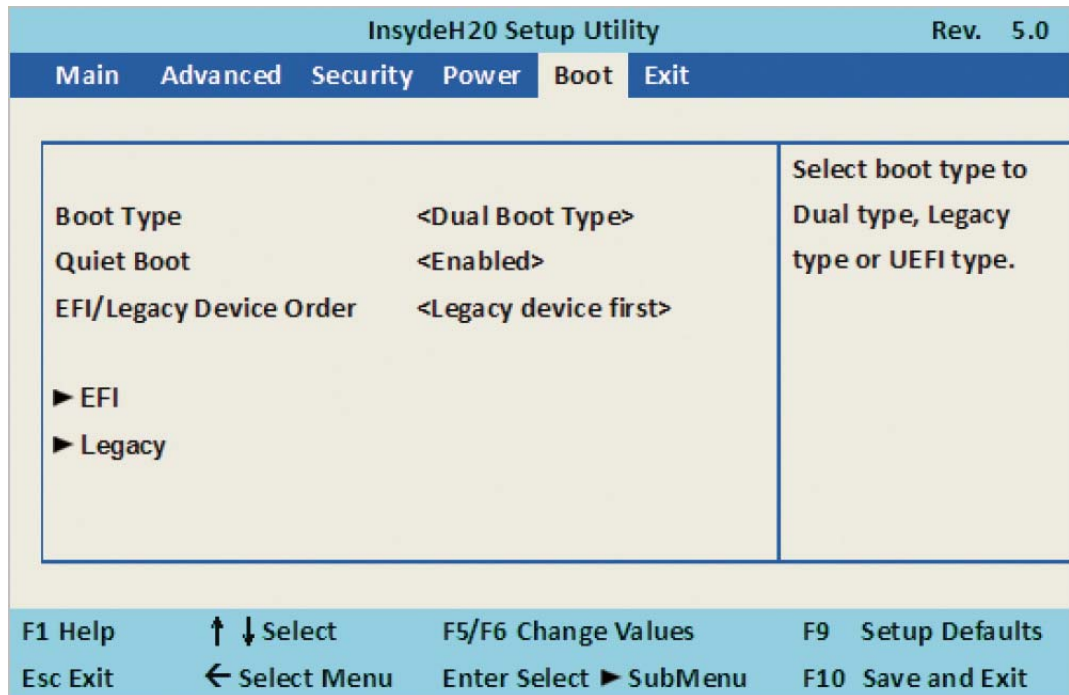

- **Boot Type.** Options are Dual type (default), Legacy boot type, UEFI boot type.
- **Quiet Boot.** Options are Enabled (default), Disabled.
- **EFI/Legacy Device order.** Determine whether the EFI device boots first or the legacy device. Options are EFI device first, Legacy device first (default), smart mode.
 - **Boot Device Priority, Normal Boot Menu.** Select Normal Boot option priority or Advance Boot option priority. Options are Normal (default), Advance.
 - **Boot Type Order.** Setting the boot type priority. The default setting is 1. USB drive 2. Hard Disk Drive 3. CD/DVD ROM drive 4. Others.

8.4.6 Exit Menu

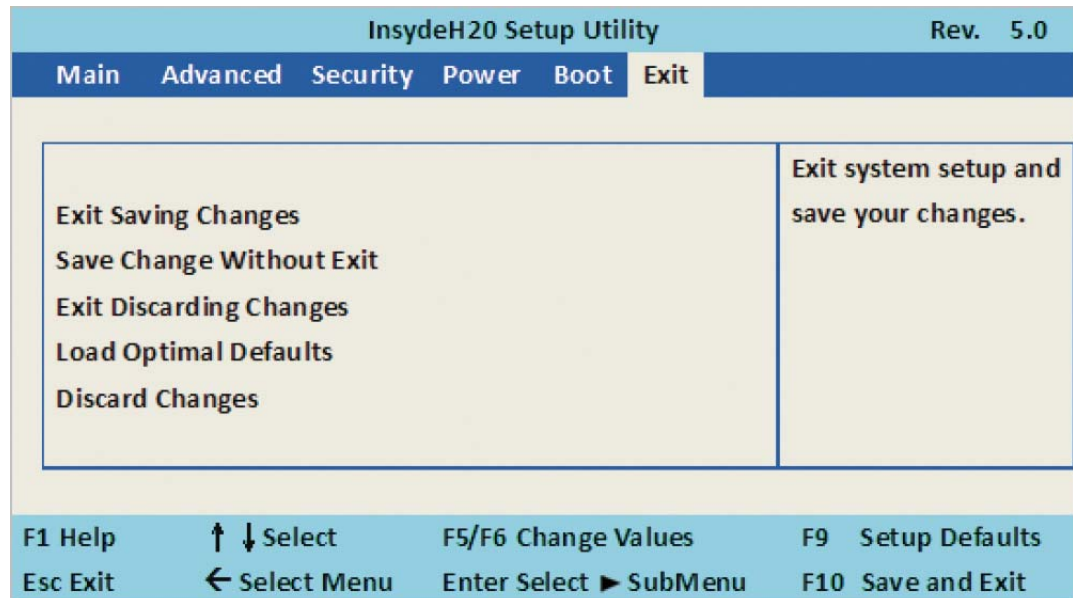

- **Exit Saving Changes.** This item allows the user to reset the system after saving the changes.
- **Save Change Without Exit.** This item allows the user to save the changes, but doesn't restart.
- **Exit Discard Changes.** This item allows the user to restart the system, but does not save the changes
- **Load Optimal Defaults.** Use this item to restore the optimal default for all of the setup options.
- **Discard Changes.** Use this item to cancel all of the changes to setup options.

8.5 Super I/O Settings

Press the **F10** key during boot up to enter the Super I/O Settings menu.

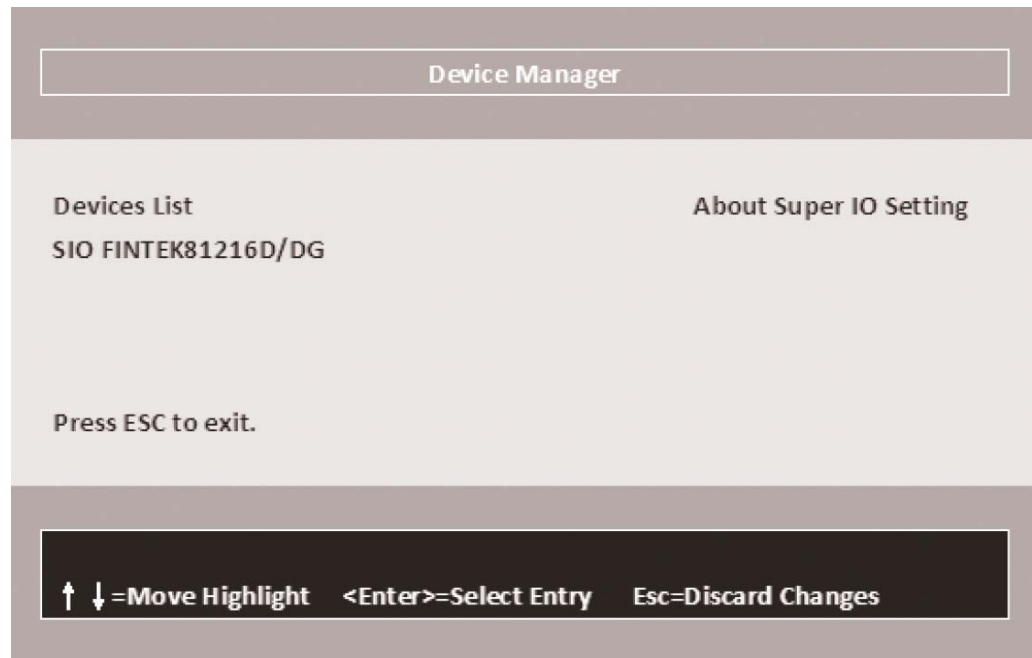

Serial Port 1 Configuration (SIO FINTEK81801U)

- **Serial Port 1 Configuration.** Use this item to enable or disable the serial port (COM1). Options are Enabled (default), Disabled.
- **Serial Port 1 Base IO Address / Interrupt / Serial Mode.** Use this item to select an I/O address and interrupt for the super IO device. Options are:
 - IO=3F8h; IRQ=4 (default)
 - IO=3E8h; IRQ=3,4
 - IO=2E8h; IRQ=3,4
 - IO=2F8h; IRQ=3,4
- **Serial Mode.** Options are:
 - RS232 driver (default): When hardware is set to RS232 or RS422 mode, select the RS232 driver.
 - RS485 driver: When hardware set to RS485 mode, select the RS485 driver. It is the auto flow function for RS485.
- **Power Failure.** This item specifies whether your system reboots after a power failure or interrupt occurs. Options are:
 - Keep state (default): Restores the system to the status before power failure or interrupt occurred.
 - Always on: Leaves the computer in the power on state.
 - Always off: Leaves the computer in the power off state.

Hardware Monitor

Press [Enter] to view the PC health status. This section shows the status of your CPU, fan, and overall system. This is only available when there is Hardware Monitor function onboard.

8.6 Glossary

- **Advanced Configuration and Power Interface (ACPI):** Specification that establishes industry standard interfaces enabling OS directed configuration, power management and thermal management of mobile, desktop, and server platforms.
- **Dynamic Video Memory Technology (DVMT):** Allows dynamic allocation of system memory for use as video memory to ensure the most efficient use of available resources in order to maximize 2D/3D graphics performance.
- **Graphics Processing Unit (GPU):** Specialized electronic circuit designed to rapidly manipulate and alter memory to accelerate the creation of images in a frame buffer.
- **Integrated Graphics Device (IGD):** Graphics processor integrated into the Bay Trail SOC. The IGD in the Bay Trail SOC is an Intel 9th Generation GPU, a.k.a. Gen9 GPU.
- **Trusted platform module (TPM):** Secure cryptoprocessor that integrates cryptographic keys into devices.
- **Trusted Execution Engine (TXE):** Computer hardware technology that is used to attest the authenticity of computer platforms and their operating systems. TXE assures that an OS starts in a trusted environment and provides the trusted OS with additional security capabilities. TXE uses a TPM and cryptographic techniques to allow system software and management applications to make trust decisions.
- **Unified Extensible Firmware Interface (UEFI):** Specification that defines a software interface between an operating system and platform firmware. UEFI replaces the Basic Input/Output System (BIOS) firmware interface

8.7 Software Description

This section provides details on the Insyde BIOS components to be used in the implementation of the ITX-F-3800 BIOS firmware.

8.7.1 Software Design Specification: UEFI Operating System Support

The BIOS supports the booting of the following UEFI compliant OSes:

- Microsoft Windows 10 x32/x64 (including Win10 IoT)
- Ubuntu 16.XX x32/x64

8.7.2 Software Design Specification: Legacy Operating System Support

- Compatibility Support Module (CSM)
- Legacy boot support required
- Legacy option ROM support required

The BIOS supports the booting of the following legacy OS:

- MS-DOS 6

8.7.3 Software Design Specification: Boot Device Configuration

The BIOS supports booting an OS from the following devices:

- USB mass storage device
- Serial ATA (SATA) device
- Network Boot - PXE
- eMMC
- M.2 mass storage device

8.7.4 Software Design Specification: BIOS Update Mechanisms

The BIOS supports the following update mechanisms:

- Software utilities
- Flash recovery via USB mass storage device

8.7.5 Software Design Requirements: BIOS Components

The BIOS includes the following components:

- **Advanced Host Controller Interface (AHCI) support:** Provides SATA host controller functionality.
- **Boot order:** Generates the default boot order on the platform's first boot.
- **Boot/resume from S4 device:** allows the platform to boot from the last S4 hibernated device, disregarding the current boot priority.
- **Fastboot:** Provides optimization of the boot time.
- **Fixed boot order:** Provides infrastructure that allows custom handling of available boot options to meet specific customer needs. Custom boot behavior may include different requests, such as always boot from specific device, default support of various kinds of grouping of boot devices
- **Generic error logging:** Provides support for logging POST and runtime errors to the GPNV area.
- **Keyboard controller emulation** for USB keyboard/mouse.
- **Physical memory testing:** Supports testing of physical memory present in the system.
- RTC registration and ability to handle wakeup from S5 sleep state.

8.8 BIOS Update with UEFI Shell

8.8.1 Scope

The Unified Extensible Firmware Interface (EFI or UEFI for short) is a new model for the interface between operating systems and firmware. It provides a standard environment for booting an operating system and running pre-boot applications.

An optional feature of a UEFI implementation is the ability to boot the system to a built-in shell. The UEFI shell provides a command prompt and a rich set of commands that extend and enhance the UEFI BIOS's capability.

This section describes the process for updating the ITX-F-3800 BIOS firmware image using the built-in UEFI shell.

8.8.2 Process

1. Insert a USB flash drive containing the BIOS update program into a USB socket on the ITX-F-3800 platform.
2. Turn on the ITX-F-3800 and press the **ESC** or **DEL** key during the boot process, which starts the BIOS setup utility.
3. In the BIOS setup utility, use the cursor keys to highlight the **Save & Exit** menu option.
4. Use the cursor keys to select **UEFI: Built-In EFI Shell** from the list of boot devices displayed under the **Boot Override** section.
5. Press **Enter**.

The PX1-C415 executes the built-in UEFI shell, and displays a list of attached storage devices. The USB flash drive shows up in the list; depending on other boot devices attached, it may be listed as **fs0**, **fs1**, etc.

6. From the UEFI shell command prompt, enter the following command where **N** is the number of the fs device representing the USB flash drive:

```
fsN:
```

Example: `fs1:`

The shell prompt changes to indicate that device `fsN` is now the active storage device, e.g., `fs1:`

7. Execute the following command:

```
ls
```

The output of the `ls` command is similar to the display listing available with the Linux or MS-DOS `list` directory command. If the correct storage device was selected in step 6 above, the `ls` command `f` should show the BIOS update program in the directory listing obtained with the `ls` command.

8. Assuming the BIOS update program is named `Update.efi`, enter the following command at the shell command prompt:

```
Update.efi
```

The BIOS update program begins executing.

9. When the update program completes, power cycle the platform to force the new BIOS image to load and execute.
10. Verify BIOS update was successful by comparing displayed BIOS version with version specified in the BIOS update notification.

9. Accessories and Cables

9.1 Package Contents

The following items are included in the package:

- One ITX-F-3800 main board
- One passive heat spreader
- One power cable adapter

9.2 Accessory List

WinSystems cables simplify connection to the ITX-F-3800. The following table lists available items.

Table 3: Cable specifications

Part Number	Connection	Description
CBL-PWR-B02-04A	See “PWR - DC Power Input” on page 19	1x2 pin (2.0 mm) to 5.5 x 2.5 mm barrel connector
CBL-PANEL-J02-06A	See “FPH - Front Panel Pin Header” on page 14	2x5 pin (2.0 mm) to Power and Reset buttons, as well as Power, HDD, LAN status LEDs
CBL-AUDIO2-J02-06A	See “AUDIO - Audio interface” on page 12	2x5 pin (2.0 mm) to 1x Line Out, 1x Mic In 3.5 mm female audio jacks
CBL-SER1-J02-06A	See “COM1 - COM Interface” on page 12	2x5 pin (2.0 mm) to 1x DB-9 connector
CBL-VGA-J02-06A	See “VGA - Analog VGA Display” on page 14	2x5 pin (2.0 mm) to 1x DE-15 connector
CBL-DIO8-J01-06A	See “DIO - Digital Input/Output” on page 15	2x5 pin (2.0 mm) to 2x5 pin (2.0 mm)
CBL-ENET1-J02-06A	See “LAN1 - LAN 10/100/1000 Ethernet Interface” on page 16	2x4 pin (2.0 mm) to 2x4 pin (2.0 mm)
ADP-IO-ENET-003A	See “LAN1 - LAN 10/100/1000 Ethernet Interface” on page 16	2x4 pin (2.0 mm) to 1x RJ-45 adapter board
CBL-LED2-J02-08A	See “LED1 - Ethernet LED” on page 17	1x4 pin (1.25 mm) to 1x4 pin (1.25 mm)
CBL-USB1-J02-08A	See “USB1-USB5 - USB Interface” on page 20	1x4 pin (1.25 mm) to 1x USB Type A connector
CBL-USB1-J03-08A	See “USB1-USB5 - USB Interface” on page 20	1x5 pin (1.25 mm) and 1x4 pin (1.25 mm) to 2x5 pin (1.25 mm)
ADP-IO-USB-003A	See “USB1-USB5 - USB Interface” on page 20	2x5 pin (1.25 mm) to 1x USB 3.1 Gen 1 Type A adapter board

Standoff kits are available and recommended for use with the ITX-F-3800. The following table lists the items contained in each kit.

Table 4: Standoff kits

Kit	Component	Description	Qty
KIT-PCM-STANDOFF-4 4 pc. nylon hex standoff kit	Standoff	Nylon 0.25" hex, 0.600" long male/female 4-40	4
	Hex nut	Hex nylon 4-40	4
	Screw	Phillips-pan head (PPH) 4-40 x 1/4" stainless steel	4
KIT-PCM-STANDOFF-B-4 4 pc. brass hex standoff kit	Standoff	Brass 5 mm hex, 0.600" long male/female 4-40	4
	Hex nut	4-40 x 0.095 Thick, Nickel Finish	4
	Screw	Phillips-pan head (PPH) 4-40 x 1/4" stainless steel	4

10. Software Drivers

Go to www.winsystems.com for information on available software drivers.

Appendix A. Best Practices

The following paragraphs outline the best practices for operating the ITX-F-3800 in a safe, effective manner, that does not damage the board. Read this section carefully.

Power Supply



Avoid Electrostatic Discharge (ESD)

Only handle the circuit board and other bare electronics when electrostatic discharge (ESD) protection is in place. Having a wrist strap and a fully grounded workstation is the minimum ESD protection required before the ESD seal on the product bag is broken.

Power Supply Budget

Evaluate your power supply budget. It is usually good practice to budget twice the typical power requirement for all of your devices.

Zero-load Power Supply

Use a zero-load power supply whenever possible. A zero-load power supply does not require a minimum power load to regulate. If a zero-load power supply is not appropriate for your application, then verify that the single board computer's typical load is not lower than the power supply's minimum load. If the single board computer does not draw enough power to meet the power supply's minimum load, then the power supply does not regulate properly and can cause damage to the ITX-F-3800.



Use Proper Power Connections (Voltage)

When verifying the voltage, measure it at the power connector on the ITX-F-3800. Measuring it at the power supply does not account for voltage drop through the wire and connectors.

The ITX-F-3800 requires +9V to +36V (+- 5%) to operate. Verify the power connections. Incorrect voltages can cause catastrophic damage.

The ITX-F-3800 has a single power connector at J17. A single 9V-36V DC input and ground is required to power the board.

Power Harness

Minimize the length of the power harness. This reduces the amount of voltage drop between the power supply and the ITX-F-3800.

Gauge Wire

Use the largest gauge wire that you can. Most connector manufacturers have a maximum gauge wire they recommend for their pins.

Contact Points

Some manufacturers use connectors with gold finish contacts. Gold finish contacts are used exclusively on high-speed connections. Power and lower speed peripheral connectors may use a tin finish as an alternative contact surface. It is critical that the contact material in the mating connectors is matched properly (gold to gold and tin to tin). Contact areas made with dissimilar metals can cause oxidation/corrosion, resulting in unreliable connections.

Pin Contacts

Often the pin contacts used in cabling are not given enough attention. The ideal choice for a pin contact would include a design similar to Molex or Trifurcon designs, which provide three distinct points to maximize the contact area and improve connection integrity in high shock and vibration applications.

Power Down

Make sure that power has been removed from the system before making or breaking any connections.



Power Supply OFF—Always turn off the power supply before connecting to the I/O Module. Do not hot-plug the ITX-F-3800 on a host platform that is already powered.

I/O Connections OFF—Turn off all I/O connections before connecting them to the embedded computer modules or any I/O cards. Connecting hot signals can cause damage whether the embedded system is powered or not.

Mounting and Protecting the I/O Module

Placing the ITX-F-3800 on mounting standoffs—Be careful when placing the ITX-F-3800 on the mounting standoffs. Sliding the board around until the standoffs are visible from the top can cause component damage on the bottom of the board.

Do not bend or flex the ITX-F-3800—Bending or flexing can cause irreparable damage. Embedded computer modules are especially sensitive to flexing or bending around ball grid array (BGA) devices. BGA devices are extremely rigid by design, and flexing or bending the embedded computer module can cause the BGA to tear away from the printed circuit board.

Mounting holes—The mounting holes are plated on the top, bottom, and through the barrel of the hole, and are connected to the embedded computer module's ground plane. Traces are often routed in the inner layers right below, above, or around the mounting holes.

- Never use a drill or any other tool in an attempt to make the holes larger.

- Never use screws with oversized heads. The head could come in contact with nearby components causing a short or physical damage.
- Never use self-tapping screws; they compromise the walls of the mounting hole.
- Never use oversized screws that cut into the walls of the mounting holes.
- Always use all of the mounting holes. By using all of the mounting holes, you provide the support the embedded computer module needs to prevent bending or flexing.

Plug or unplug connectors only on fully mounted boards—Never plug or unplug connectors on a board that is not fully mounted. Many of the connectors fit rather tightly and the force needed to plug or unplug them could cause the embedded computer module to be flexed.

Avoid cutting the ITX-F-3800—Never use star washers or any fastening hardware that cut into the ITX-F-3800.

Avoid over-tightening of mounting hardware—Causing the area around the mounting holes to compress could damage interlayer traces around the mounting holes.

Use appropriate tools—Always use tools that are appropriate for working with small hardware. Large tools can damage components around the mounting holes.

Avoid conductive surfaces—Never allow the embedded computer module to be placed on a conductive surface. Many embedded systems use a battery to back up the clock-calendar and CMOS memory. A conductive surface such as a metal bench can short the battery causing premature failure.

Conformal Coating

Conformal coating by any source other than WINSYSTEMS voids the product warranty and will not be accepted for repair by WINSYSTEMS. If such a product is sent to WINSYSTEMS for repair, it will be returned at customer expense and no service will be performed. A WINSYSTEMS product conformally coated by WINSYSTEMS will be subject to regular WINSYSTEMS warranty terms and conditions.

Operations/Product Manuals

Every single board computer has an Operations manual or Product manual.

Periodic Updates—Operations/Product manuals are updated often. Periodically check the WinSystems website (<http://www.winsystems.com>) for revisions.

Check Pinouts—Always check the pinout and connector locations in the manual before plugging in a cable. Many I/O modules have identical headers for different functions and plugging a cable into the wrong header can have disastrous results.

Contact an Applications Engineer—If a diagram or chart in a manual does not seem to match your board, or if you have additional questions, contact a WinSystems Applications Engineer at +1-817-274-7553.

Appendix B. Mechanical Drawings

ITX-F-3800 Mechanical Drawings

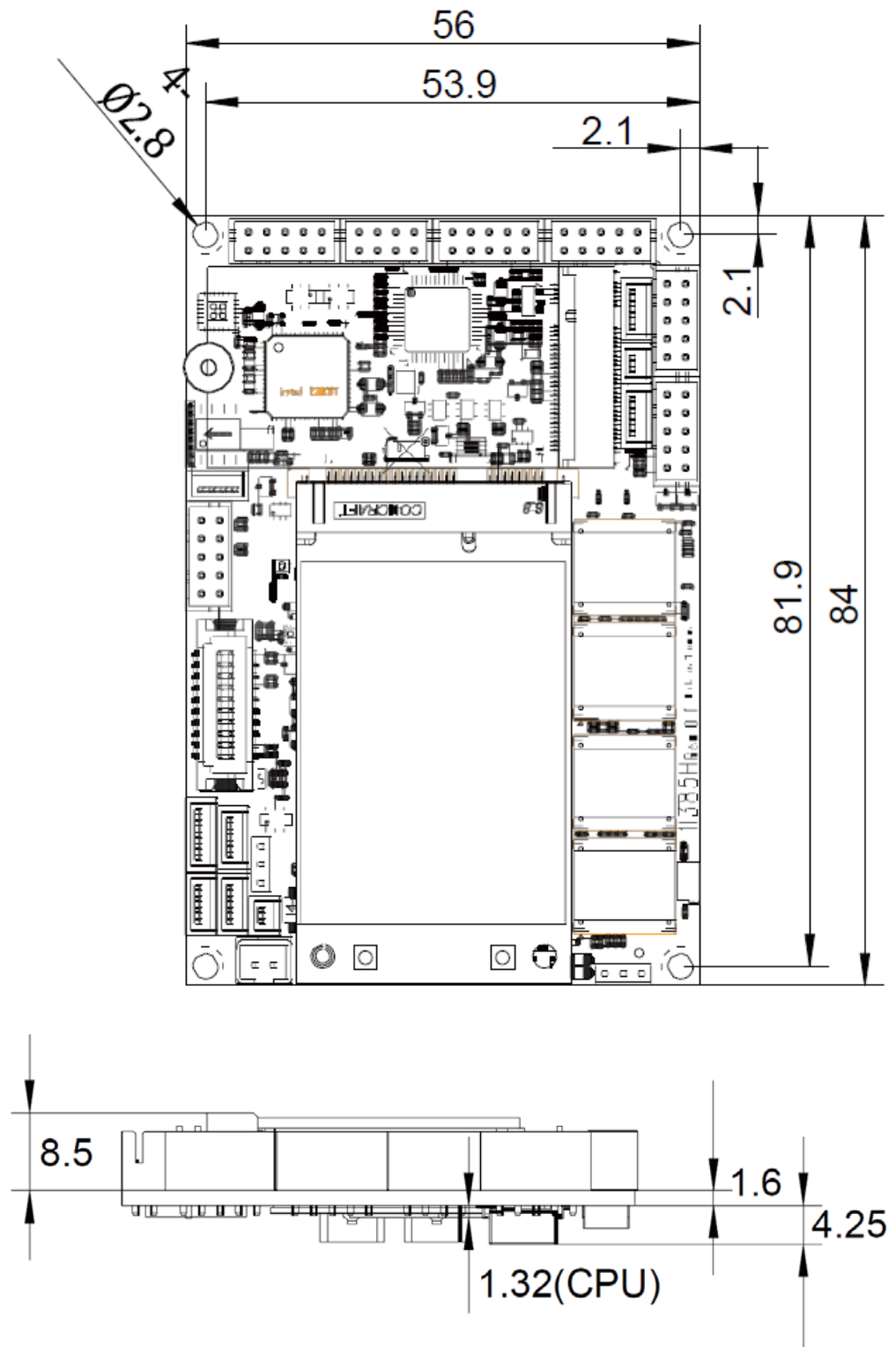

Appendix C. Warranty Information

Full warranty information can be found at <https://winsystems.com/company-policies/warranty/>.