

# SYS-427X

Industrial Embedded Computer with  
Intel® Atom™ x7-E3950 processor,  
Dual Ethernet, Multi-Display, and Expansion

## Product Manual



## Revision History

| Document Version | Last Updated Date | Brief Description of Change                                   |
|------------------|-------------------|---|
| v1.0             | 02/20/2024        | Initial release   |
| v1.1             | 07/24/2024        | Removed Block Diagram and Cables sections                     |
| v1.2             | 08/06/2024        | Updated system photos and drawings                            |
| v1.3             | 08/29/2025        | Updated conformal coating, warranty and web links information |
| v1.4             | 06/15/2026        | Added model options and various corrections                   |

## Copyright and Trademarks

Copyright 2026, WINSYSTEMS, Inc.

No part of this document may be copied or reproduced in any form or by any means without the prior written consent of WINSYSTEMS, Inc. The information in the document is subject to change without notice. The information furnished by WINSYSTEMS, Inc. in this publication is believed to be accurate and reliable. However, WINSYSTEMS, Inc. makes no warranty, express, statutory, implied or by description, regarding the information set forth herein or regarding the freedom of the described devices from patent infringement. WINSYSTEMS, Inc. makes no warranty of merchantability or fitness for any purpose. WINSYSTEMS, Inc. assumes no responsibility for any errors that may appear in this document.

### Trademark Acknowledgments

WINSYSTEMS is a registered trademark of WINSYSTEMS, Inc.

Mili-grid is a trademark of Molex, Inc.

The terms HDMI, HDMI High-Definition Multimedia Interface, and the HDMI Logo are trademarks or registered trademarks of HDMI Licensing Administrator, Inc.

Arm and Cortex are registered trademarks of Arm Limited (or its subsidiaries) in the US and/or elsewhere.

Intel and Intel Atom are trademarks of Intel Corporation.

All other marks are the property of their respective companies.

# Table of Contents

|            |   |           |
|------------|---|-----------|
| <b>1</b>   | <b>Before You Begin</b> .....                             | <b>6</b>  |
| <b>1.1</b> | <b>Warnings</b> .....                                     | <b>6</b>  |
| <b>2</b>   | <b>Introduction</b> .....                                 | <b>6</b>  |
| <b>3</b>   | <b>Functionality</b> .....                                | <b>7</b>  |
| <b>4</b>   | <b>Features</b> .....                                     | <b>8</b>  |
| <b>5</b>   | <b>General Operation</b> .....                            | <b>10</b> |
| <b>6</b>   | <b>Specifications</b> .....                               | <b>11</b> |
| <b>7</b>   | <b>Configuration</b> .....                                | <b>15</b> |
| <b>7.1</b> | <b>Component Layout</b> .....                             | <b>15</b> |
| 7.1.1      | Front and Rear View .....                                 | 15        |
| 7.1.2      | Top View .....  | 16        |
| 7.1.3      | Bottom View .....   | 18        |
| <b>7.2</b> | <b>Connectors and Buttons</b> .....                       | <b>19</b> |
| 7.2.1      | Power Button .....  | 19        |
| 7.2.2      | Power Input Connector .....                               | 19        |
| 7.2.3      | J15/J16 Ethernet (LAN) Dual RJ45 .....                    | 20        |
| 7.2.4      | J17 USB 3.1 Gen 1 Type-A Connector .....                  | 21        |
| 7.2.5      | J10/J11 USB 2.0 Type-A Connector .....                    | 22        |
| 7.2.6      | J18/J19 Display Ports .....                               | 23        |
| 7.2.7      | COM1 COM2 and COM3 .....                                  | 24        |
| 7.2.8      | Audio Jack (Combo Line Out/Mic In and PC Speaker) .....   | 25        |
| 7.2.9      | GPIO Connector .....                                      | 26        |
| 7.2.10     | J20 - Input Power Header .....                            | 27        |
| 7.2.11     | J12 - Power Module Header (Internal) .....                | 28        |
| 7.2.12     | J8 - Battery Header (Internal) .....                      | 29        |
| 7.2.13     | J7 - SATA Power Header (Internal) .....                   | 30        |
| 7.2.14     | J13 - Fan Header (Internal) .....                         | 30        |
| 7.2.15     | J6 - LVDS Data and Backlight Header (Internal) .....      | 31        |
| 7.2.16     | J504 - USB Touchscreen Header (Internal) .....            | 32        |
| 7.2.17     | SP500 - Speaker (Internal) .....                          | 33        |
| 7.2.18     | J2 - HD Audio Header (Internal) .....                     | 33        |
| 7.2.19     | J1 - Legacy RS232 Header (Internal) .....                 | 34        |
| 7.2.20     | J4 - Serial Ports (RS232/422/485) Header (Internal) ..... | 35        |

|             |  |           |
|-------------|--|-----------|
| 7.2.21      | J10/J11 - USB 2.0 Port 2x Headers (Internal) . . . . .                   | 36        |
| 7.2.22      | J3 - Serial SATA 6Gbps Connector (Internal) . . . . .                    | 37        |
| 7.2.23      | J500 - RAM Connector (Internal) . . . . .                                | 37        |
| 7.2.24      | J5 - GPIO General-Purpose Input/Output Header (Internal) . . . . .       | 38        |
| 7.2.25      | J14 - Analog Inputs (Analog to Digital) Header (Internal) . . . . .      | 39        |
| 7.2.26      | J502 - Modular IO80 (Internal) . . . . .                                 | 40        |
| 7.2.27      | J503 - M.2 Socket 1, with E key (Internal) . . . . .                     | 41        |
| 7.2.28      | J501 - Mini PCIe (with mSATA Support) (Internal) . . . . .               | 41        |
| <b>7.3</b>  | <b>Jumpers . . . . .</b>   | <b>41</b> |
| 7.3.1       | JP1 - Board Configuration Jumpers (Internal) . . . . .                   | 41        |
| <b>7.4</b>  | <b>LED Indicators . . . . .</b>  | <b>42</b> |
| <b>7.5</b>  | <b>Watchdog Timer (WDT) . . . . .</b>                                    | <b>43</b> |
| 7.5.1       | WDT Register Usage . . . . .   | 43        |
| <b>7.6</b>  | <b>Real-time Clock/Calendar . . . . .</b>                                | <b>43</b> |
| <b>7.7</b>  | <b>System Management Software . . . . .</b>                              | <b>43</b> |
| <b>8</b>    | <b>BIOS Functionality . . . . .</b>                                      | <b>44</b> |
| <b>8.1</b>  | <b>Software Description . . . . .</b>                                    | <b>44</b> |
| 8.1.1       | Software Design Specification: UEFI Operating System Support . . . . .   | 44        |
| 8.1.2       | Software Design Specification: Legacy Operating System Support . . . . . | 44        |
| 8.1.3       | Software Design Specification: Boot Device Configuration . . . . .       | 44        |
| 8.1.4       | Software Design Specification: BIOS Update Mechanisms . . . . .          | 45        |
| 8.1.5       | Software Design Requirements: BIOS Components . . . . .                  | 45        |
| <b>8.2</b>  | <b>BIOS Update with UEFI Shell . . . . .</b>                             | <b>46</b> |
| 8.2.1       | Scope . . . . .  | 46        |
| 8.2.2       | Process . . . . .  | 46        |
| <b>8.3</b>  | <b>Embedded Controller (EC) Update with UEFI Shell . . . . .</b>         | <b>47</b> |
| 8.3.1       | Scope . . . . .  | 47        |
| 8.3.2       | Process . . . . .  | 48        |
| <b>9</b>    | <b>Software Drivers . . . . .</b>  | <b>49</b> |
| <b>10</b>   | <b>Options . . . . .</b>   | <b>49</b> |
| <b>10.1</b> | <b>Standard Model . . . . .</b>  | <b>49</b> |
| <b>10.2</b> | <b>Option 1 . . . . .</b>  | <b>50</b> |
| <b>10.3</b> | <b>Option 2 . . . . .</b>  | <b>51</b> |
| <b>10.4</b> | <b>Option 3 . . . . .</b>  | <b>52</b> |

|           |                                   |           |
|-----------|-----------------------------------|-----------|
| <b>11</b> | <b>Accessories</b> .....          | <b>53</b> |
| <b>A</b>  | <b>Best Practices</b> .....       | <b>54</b> |
| <b>B</b>  | <b>Mechanical Drawings</b> .....  | <b>57</b> |
| <b>C</b>  | <b>Warranty Information</b> ..... | <b>58</b> |

# 1. Before You Begin

Review the warnings in this section and the best practice recommendations (See “Best Practices” on page 54.) when using and handling the WINSYSTEMS SYS-427X industrial computer. Following these recommendations provides an optimal user experience and prevents damage. Read through this document and become familiar with the SYS-427X before proceeding.



APPLYING CONFORMAL COATING AFTER PURCHASE WILL VOID YOUR WARRANTY. FAILING TO COMPLY WITH THESE BEST PRACTICES MAY DAMAGE THE PRODUCT AND VOID YOUR WARRANTY.

## 1.1 Warnings

Only qualified personnel should configure and install the SYS-427X. While observing best practices, pay particular attention to the following.



### **Avoid electrostatic discharge (ESD)**

Only handle the circuit board and other bare electronics when electrostatic discharge (ESD) protection is in place. Having a wrist strap and a fully grounded workstation is the minimum ESD protection required before the ESD seal on the product bag is broken.

# 2. Introduction

This manual provides configuration and usage information for the SYS-427X. If you still have questions, contact Technical Support at (817) 274-7553, Monday through Friday, between 8 AM and 5 PM Central Standard Time (CST).

### 3. Functionality

The SYS-427X is a rugged, embedded computer featuring the energy efficient and rugged Intel Atom<sup>®</sup> Apollo Lake x7-E3950 processor.

The SYS-427X computer supports two video DisplayPorts, dual Ethernet jacks, two USB 3.1 Gen 1 ports, two USB 2.0 ports, eight general purpose I/O (GPIO) lines, one RS232 COM port, two RS232/422/485 COM ports and one Line Out/Mic In / PC Speaker jack.

Standard solid state storage includes a soldered down 64GB eMMC chip for operating systems (OS) and applications. The SYS-427X computer includes 8GB of socketed SODIMM DDR3L Error Correcting Code (ECC) SDRAM.

CAN bus and WiFi 6 moduals are available, as are 2.5" SATA SSD and other accessories. For details, refer to ["Options" on page 49](#) and ["Accessories" on page 53](#) of this manual. Ordered accessories come installed on your system.

## 4. Features

The SYS-427X industrial PC provides the following features.

### Processor

- Intel Atom® Processor X Series
  - Processor Number - x7-E3950
  - Code Name - Apollo Lake
- CPU Specifications
  - Total Cores - 4
  - Total Threads - 4
  - Burst Frequency - 2.00 GHz
  - Processor Base Frequency - 1.60 GHz
  - Cache - 2 MB L2 Cache
  - TDP - 12 W
- GPU Specifications
  - GPU Name - Intel® HD Graphics 505
  - Graphics Base Frequency - 500 MHz
  - Graphics Burst Frequency - 650 MHz
  - Graphics Video Max RAM- 2GB
  - Graphics Output - eDP/DP/HDMI/MIPI-DSI
  - 4K Support - Yes, at 60Hz
  - Max Resolution (HDMI) - 3840x2160 @30Hz
  - Max Resolution (DP) - 4096x2160 @60Hz
  - Max Resolution - eDP - Integrated Flat Panel) 3840x2160 @ 60Hz
  - # of Displays Supported - 3
- Reliability

Intel security engine - Intel® AES New Instructions, Secure Key, Execute Disable Bit, Intel® Virtualization Technology (VT-x), Intel® Virtualization Technology for Directed I/O (VT-d), Intel® VT-x with Extended Page Tables (EPT)

### Operating Systems (compatibility)

- Windows 10 x64, IoT Core
- Linux x64
- Other x86 operating systems (Please inquire our sales team for more operating system options.)

**BIOS**

- AMI UEFI-compliant BIOS

**Video Interfaces (Can support up to two simultaneous displays)**

- 2x DisplayPort (version 1.2)
- 4096 x 2160 at 60 Hz

**Ethernet**

- 2x Intel 10/100/1000 Mbps controllers using Intel i210
- Wake-on-LAN support, both channels

**RAM**

- 8 GB of socketed SODIMM DDR3L Error Correcting Code (ECC) SDRAM

**Internal Storage**

- Soldered down 64 GB eMMC

**Internal Storage Options**

- SATA 6Gb/s port supports up to 2.TB on a 2.5" SSD drive
- SATA Version- 3.1
- mSATA SSD support (Mini PCIe card)

**Internal Bus Expansion**

- M.2 E-Key socket (2230)
- Mini PCIe socket (Full Size, PCIe, USB, SATA)

**Serial Interface**

- 2x RS232/422/485 serial ports (COM1 and COM2)
- 1x RS232 serial port (COM3)

**USB**

- Available on the front I/O panel
- 2x USB 3.1 Gen 1 ports
- 2x USB 2.0 ports

**Power**

- Supports a wide range DC input power: 10 V to 50 V

## Industrial Operating Temperature

- -40° to +85°C (-40° to +185°F)
- Relative Humidity 10% to 95% (non-condensing)

## Additional Specification

- Watchdog timer adjustable from 1 second to 255 minute reset
- CE and RoHS compliant

# 5. General Operation

WINSYSTEMS' SYS-427X I/O panel supports two DisplayPorts, dual Ethernet, two USB 3.1 Gen 1 ports, two USB 2.0 ports, three COM ports, eight general purpose I/O (GPIO) lines, and a Line Out/Mic In / PC Speaker jack.

The WINSYSTEMS SYS-427X features a quad-core processor and 8GB of socketed SODIMM DDR3L ECC SDRAM. The embedded computer includes an mSATA socket and a soldered down 64GB eMMC device for solid state storage of operating systems and applications. Additionally, the computer supports an optional internal SATA device.

The SYS-427X has expansion capabilities via a M.2 Socket 1 with E key, Mini PCIe socket (with mSATA support) and WINSYSTEMS Modular IO80 interface.

The embedded computer supports Linux, Windows 10, and other x86-compatible real-time operating systems. Drivers are available from the WINSYSTEMS website.

## 6. Specifications

The SYS-427X adheres to the following features and specifications.

| Feature            | Specification  |
|--------------------|--|
| <b>System</b>      |  |
| Processor          | <ul style="list-style-type: none"> <li>- Intel Atom® Processor X Series</li> <li>- Processor - x7-E3950</li> <li>- Code Name - Apollo Lake</li> </ul>  |
| CPU Specifications | <ul style="list-style-type: none"> <li>- Total Cores - 4</li> <li>- Total Threads - 4</li> <li>- Burst Frequency - 2.00 GHz</li> <li>- Processor Base Frequency - 1.60 GHz</li> <li>- Cache - 2 MB L2 Cache</li> <li>- TDP - 12 W</li> </ul>   |
| GPU Specifications | <ul style="list-style-type: none"> <li>- GPU Name - Intel® HD Graphics 505</li> <li>- Graphics Base Frequency - 500 MHz</li> <li>- Graphics Burst Frequency - 650 MHz Graphics Video - Max RAM- 2GB</li> <li>- Graphics Output - eDP/DP/HDMI/MIPI-DSI</li> <li>- 4K Support - Yes, at 60Hz</li> <li>- Max Resolution (HDMI) - 3840x2160 @30Hz</li> <li>- Max Resolution (DP) - 4096x2160 @60Hz</li> <li>- Max Resolution - eDP - Integrated Flat Panel) 3840x2160 @ 60Hz</li> <li>- # of Displays Supported - 2</li> </ul> |
| Reliability        | <ul style="list-style-type: none"> <li>-Intel security engine - Intel® AES New Instructions, Secure Key,</li> <li>-Execute Disable Bit, Intel® Virtualization Technology (VT-x), Intel®</li> <li>-Virtualization Technology for Directed I/O (VT-d), Intel® VT-x with</li> <li>-Extended Page Tables (EPT)</li> </ul>  |
| RAM                | 8GB ECC DDR3L SODIMM (socketed)  |
| Watchdog           | Watchdog timer adjustable from 1 second to 255 minute reset  |
| TPM                | Hardware Security - Trusted Platform Module (TPM) 2.0 Enabled  |

| Feature                                   | Specification  |
|---|--|
| <b>Internal Storage / Storage Options</b> |  |
| eMMC                                      | 64 GB eMMC for on-board storage  |
| Internal SATA with SATA Power             | SATA 6Gb/s port supports up to 2.TB on a 2.5" SSD drive<br>SATA Version- 3.1 |
| Internal mSATA                            | mSATA SSD support (Mini PCIe card)   |
| <b>Internal Expansion Options</b>         |  |
| Mini PCIe                                 | Mini PCIe socket (Full Size, PCIe, USB, SATA)                                |
| M.2 E-Key                                 | M.2 E-Key socket (2230)  |
| <b>Power</b>                              |  |
| Power Mode                                | AT, ATX  |
| V <sub>CC</sub>                           | Supports a wide range DC input power: 10V to 50V                             |
| Power Connector                           | Phoenix Contact Terminal Block Header  |
| Maximum Power Usage                       | 30W  |
| <b>Mechanical</b>                         |  |
| Dimensions                                | 6.5 in x 4.5 in x 2.5 in<br>(165 mm x 11.3 mm x 3.5 mm)                      |
| Weight                                    | 38.09 oz (1.08kg)  |
| Construction                              | Heavy Duty Aluminum  |
| Mounting Options                          | Wall mounting<br>SIDE / VESA / Din-Rail Mounting (Optional)                  |
| <b>Front I/O Panel</b>                    |  |
| Display Port Connectors                   | 2x DisplayPort (version 1.2)<br>4096 x 2160 at 60 Hz                         |
| USB Connectors                            | 2x USB 3.1 Gen 1 ports<br>2x USB 2.0 ports                                   |
| Serial Connectors                         | 2x RS232/422/485 serial ports (COM1 and COM2)<br>1x RS232 serial port (COM3) |

| Feature                                       | Specification  |
|---|--|
| GPIO Connectors                               | 8x GPIO bidirectional lines<br>2x analog to digital (ADC) lines<br>1x MIPI-CSI (4-Lane)<br>1x SPI bus<br>1x I2C bus  |
| Ethernet (LAN) Connectors                     | 2x Intel 10/100/1000 Mbps controllers using Intel i210<br>Wake-on-LAN support, both channels, RJ45   |
| Audio Jack                                    | Combo Line Out/Mic In / PC Speaker   |
| Power Button                                  | Power ON/OFF   |
| Operating System                              |  |
| Supports                                      | Windows 10<br>Linux x64<br>Other x86 operating systems<br>(Please ask our sales team about other operating system options.)                                |
| BIOS  |  |
| Software                                      | AMI UEFI-compliant BIOS  |
| Environment                                   |  |
| Environmental                                 | Operating Temperature: -40°C to 85°C (-40°F to +185°F)<br>Relative Humidity 10% to 95% (non-condensing)  |
| Certifications & Compliance                   | RoHS Compliant<br>Intertek Listed: 5017674 for FCC & CE compliance. Including RoHS.<br>Conforms to UL STD 62368-1 and certified to CSA STD C22.2 #62368-1. |
| Mechanical Shock                              | IEC 60068-2-27<br>40 g half-sine, 6 ms, 18 shocks  |
| Random Vibration                              | IEC 60068-2-64<br>7 g rms for all X, Y, and Z directions; 3 hours  |
| Mean Time Between Failure (MTBF) <sup>b</sup> | MTBF (hours) 171370.5013<br>MTBF (years) 19.5628   |

| Feature                     | Specification   |
|-----------------------------|---|
| <b>Ordering Information</b> |   |
| Part Numbers                | SYS-427X-0 - Standard model<br>SYS-427X-1 - CAN bus model<br>SYS-427X-2 - WiFi model<br>SYS-427X-3 - CAN bus + WiFi model |

## 7. Configuration

This section shows the fully loaded option of the SYS-427X components and configuration. For details, refer to "Options" on page 49 and "Accessories" on page 53 of this manual.

### 7.1 Component Layout

#### 7.1.1 Front and Rear View

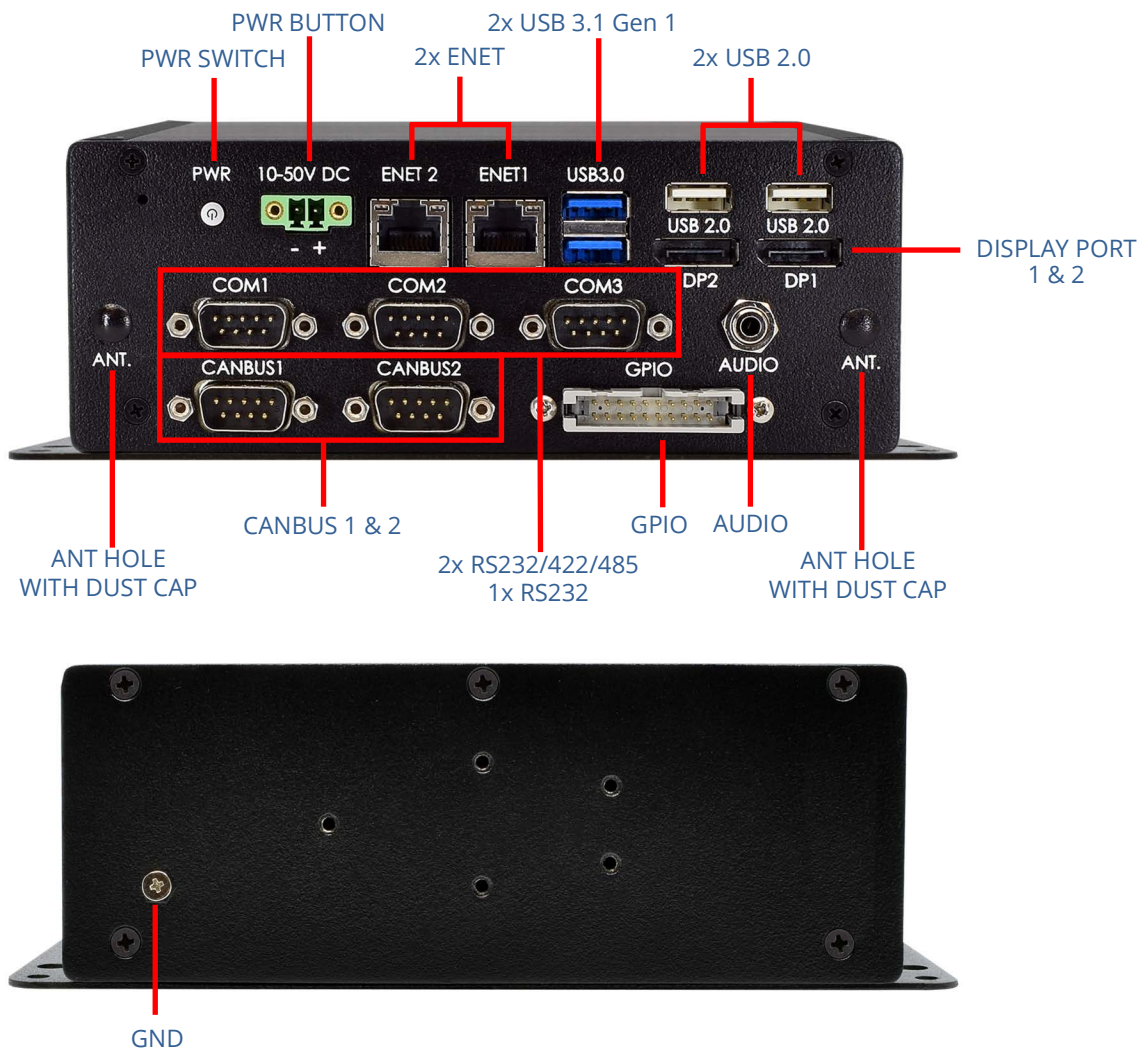

### 7.1.2 Top View

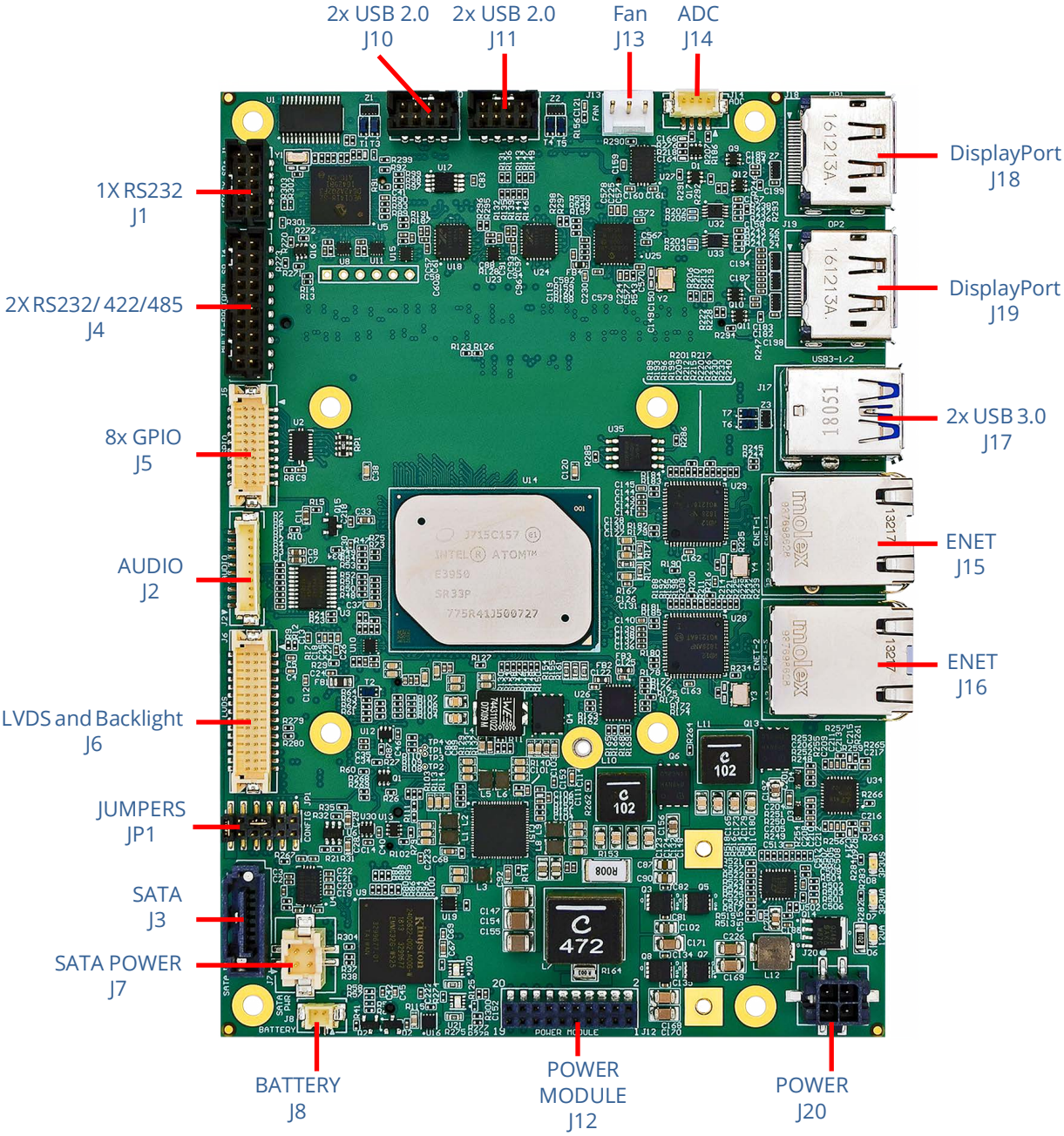

The WINSYSTEMS Front Panel Expansion Module can support connectors such as two video DisplayPorts, dual Ethernet jacks, two USB 3.1 Gen 1 ports, two USB 2.0 ports, eight general purpose I/O (GPIO) lines, one RS232 COM port, two RS232/422/485 COM ports and one Combo Line Out/Mic In / PC Speaker jack.

**NOTE** Most of the top view connectors have limited access when installed in the SYS-427X. Some connectors are used to supply connections to the front IO panel.

#### Top View Components (CPU Only)

| Item    | Description                              | Reference               |
|---------|--|-------------------------|
| J1      | Legacy RS232 Header                      | <a href="#">page 34</a> |
| J2      | HD Audio Header                          | <a href="#">page 33</a> |
| J3      | SATA 6Gb/s Port                          | <a href="#">page 37</a> |
| J4      | Serial Ports (RS232/422/485) Header      | <a href="#">page 35</a> |
| J5      | GPIO General-Purpose Input/Output Header | <a href="#">page 38</a> |
| J6      | LVDS Data and Backlight Header           | <a href="#">page 31</a> |
| J7      | SATA Power Header                        | <a href="#">page 30</a> |
| J8      | Battery Header                           | <a href="#">page 29</a> |
| J10/J11 | USB 2.0 Port 2x Headers                  | <a href="#">page 22</a> |
| J12     | Power Module Header                      | <a href="#">page 28</a> |
| J13     | Fan Header                               | <a href="#">page 30</a> |
| J14     | Analog Inputs (Analog to Digital) Header | <a href="#">page 39</a> |
| J15/J16 | Ethernet (LAN) RJ45                      | <a href="#">page 20</a> |
| J17     | USB 3.1 Gen 1 Ports                      | <a href="#">page 21</a> |
| J18/J19 | DisplayPort                              | <a href="#">page 23</a> |
| J20     | Input Power Header                       | <a href="#">page 27</a> |
| JP1     | Board Configuration Jumpers              | <a href="#">page 41</a> |

### 7.1.3 Bottom View

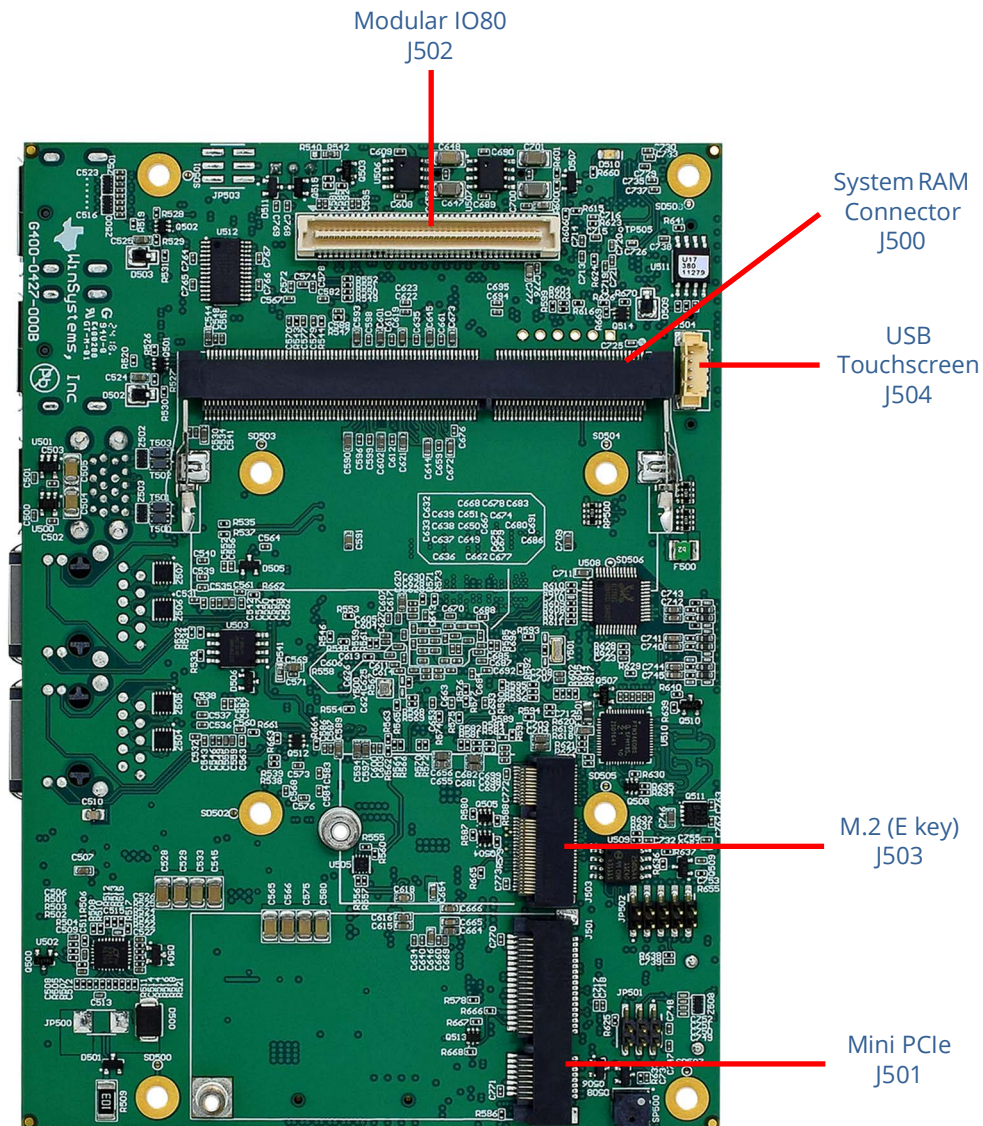

Bottom View Components

| Item | Description                    | Reference               |
|------|--------------------------------|-------------------------|
| J500 | System RAM Connector           | <a href="#">page 37</a> |
| J501 | Mini PCIe (with mSATA Support) | <a href="#">page 41</a> |
| J502 | Modular IO80                   | <a href="#">page 40</a> |
| J503 | M.2 Socket 1, with E key       | <a href="#">page 41</a> |
| J504 | USB Touchscreen Header         | <a href="#">page 32</a> |

## 7.2 Connectors and Buttons

### 7.2.1 Power Button

The Power Button is located on the left side of the IO plate. It controls power to the SYS-427X. Once the fully powered power cable is connected to the unit, it will power up the system without pressing the Power Button. Once the system is up and running you can power off and on the system using the Power Button.

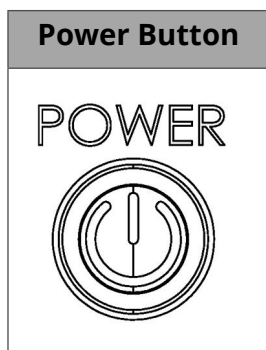

### 7.2.2 Power Input Connector

Use this connection to supply power to the SYS-427X. This computer supports a wide range DC input power from 10V to 50V. Once you connect a fully powered power cable to this connector for the first time, it will power on the system.

#### Layout and Pin Reference

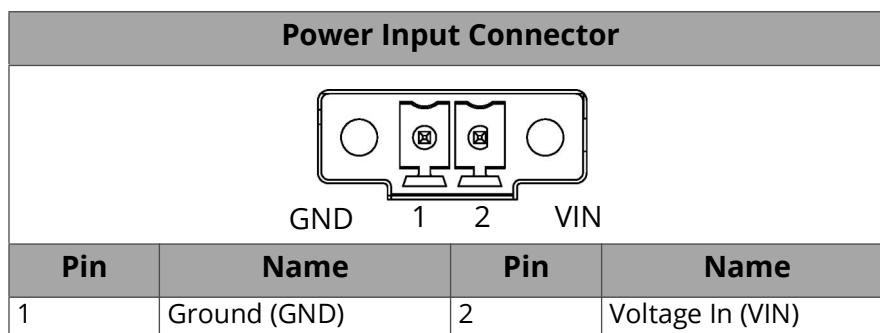

#### Connector

- Phoenix Contact terminal block header  
Part number: 1827868

#### Matching Connector

- Phoenix contact terminal block plug  
Part number: 1827703

### 7.2.3 J15/J16 Ethernet (LAN) Dual RJ45

Two Gigabit Ethernet controllers provide standard IEEE 1588 and 802.1AS protocol time-stamping. Each Ethernet interface includes 10/100/1000 Mbps multi-speed, full, and half-duplex operation.

The left RJ45 port uses an Intel i210 Ethernet controller.

The right RJ45 port uses a RGMII PHY Ethernet controller.

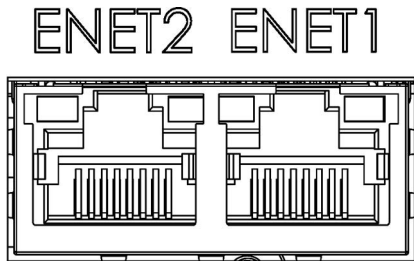
| Ethernet (LAN) Dual RJ45  |          |                      |
|---|----------|----------------------|
|  |          |                      |
| Pin   | Function | Description          |
| 1   | TX_D1+   | Transceiver Data+    |
| 2   | TX_D1-   | Transceiver Data-    |
| 3   | RX_D2+   | Receive Data+        |
| 4   | BI_D3+   | Bi-Directional Data+ |
| 5   | BI_D3-   | Bi-Directional Data- |
| 6   | RX_D2-   | Receive Data         |
| 7   | BI_D4+   | Bi-Directional Data+ |
| 8   | BI_D4-   | Bi-Directional Data- |

#### Connector

- Gigabit dual-port RJ45 connector with integrated magnetics and LEDs

#### Matching Connector

- Standard Gigabit Ethernet cables with RJ45 connectors

## 7.2.4 J17 USB 3.1 Gen 1 Type-A Connector

The SYS-427X provides two USB 3.1 Gen 1 Type A port. This port supplies 1A maximum continuous current and 5 Gbps transfer speed. When using serial downloader mode, this USB port must be used. A USB 3.0 cable is not required during serial downloader mode.

### Layout and Pin Reference

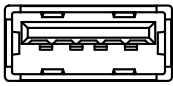
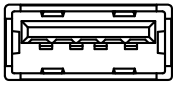
| USB 3.1 Type-A Connector |   |       |
|--------------------------|---|-------|
| PIN 4                    |  | PIN 1 |
| PIN 5                    |   | PIN 9 |
|                          |  |       |
| Pin                      | Name  |       |
| 1                        | USBVCC  |       |
| 2                        | D-  |       |
| 3                        | D+  |       |
| 4                        | GND   |       |
| 5                        | RX-   |       |
| 6                        | RX+   |       |
| 7                        | GND   |       |
| 8                        | TX-   |       |
| 9                        | TX+   |       |

### Connector

- Dual-port stacked standard USB 3.1 Gen 1 Type A

### Matching Connector

- Standard USB 3.1 Gen 1 cables and devices

## 7.2.5 J10/J11 USB 2.0 Type-A Connector

The SYS-427X provides two USB 2.0 Type A port. This port supplies 500 mA maximum continuous current and 480 Mbps transfer speed.

### Layout and Pin Reference

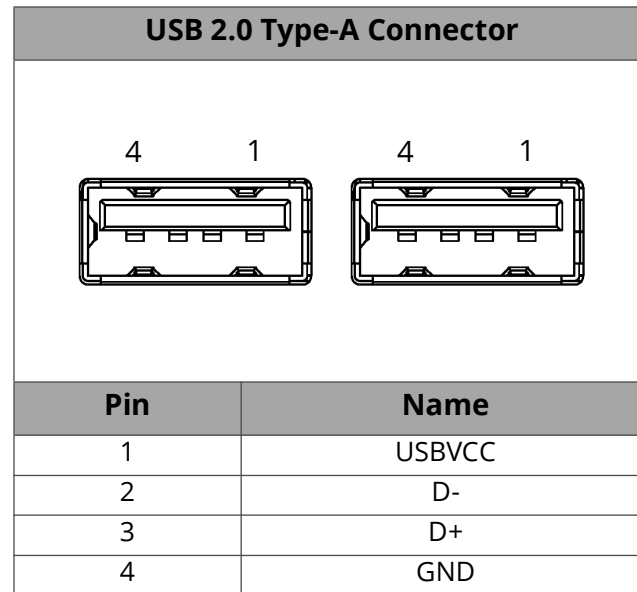

### Connector

- Standard USB 2.0 connector

### Matching Connector

- Standard USB 2.0 cables and devices

## 7.2.6 J18/J19 Display Ports

### Layout and Pin Reference

Two Standard full-size 20-pin DisplayPort (Version 1.2)

| Display Ports 1 and 2 |               |
|-----------------------|---------------|
|                       |               |
| Pin                   | Name          |
| 1                     | ML_Lane 0 (p) |
| 2                     | GND           |
| 3                     | ML_Lane 0 (n) |
| 4                     | ML_Lane 1 (p) |
| 5                     | GND           |
| 6                     | ML_Lane 1 (n) |
| 7                     | ML_Lane 2 (p) |
| 8                     | GND           |
| 9                     | ML_Lane 2 (n) |
| 10                    | ML_Lane 3 (p) |
| 11                    | GND           |
| 12                    | ML_Lane 3 (n) |
| 13                    | CONFIG1       |
| 14                    | CONFIG2       |
| 15                    | AUX CH (p)    |
| 16                    | GND           |
| 17                    | AUX CH (n)    |
| 18                    | Hot Plug      |
| 19                    | Return        |
| 20                    | DP_PWR        |

### Connector

- Molex 47272 series DisplayPort receptacle

### Matching Connector

- Standard DisplayPort compliant cable

## 7.2.7 COM1 COM2 and COM3

The SYS-427X is equipped with three serial ports (COM 1 and 2 = RS-232/422/485 / COM 3 = RS-232) located on the front IO plate. All serial channels use the advanced EXAR SP335E multi protocol transceiver. All COM ports are configurable and include options for 120-ohm receiver termination, slew rate, and protocol.

### Layout and Pin Reference

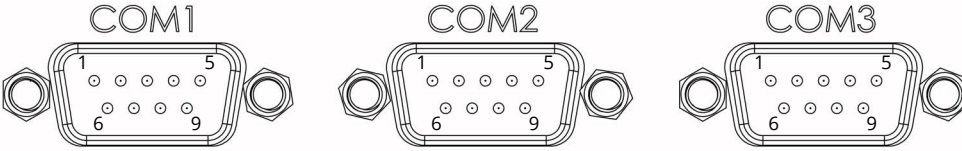
| COM Port Connectors  |        |        |        |
|--|--------|--------|--------|
|  |        |        |        |
| Pin  | RS-232 | RS-422 | RS-485 |
| 1  | DCD    | N/A    | N/A    |
| 2  | RX     | TX+    | TX/RX+ |
| 3  | TX     | RX+    | N/A    |
| 4  | DTR    | N/A    | N/A    |
| 5  | GND    | GND    | GND    |
| 6  | DSR    | TX-    | TX/RX- |
| 7  | RTS    | RX-    | N/A    |
| 8  | CTR    | N/A    | N/A    |
| 9  | RI     | N/A    | N/A    |

### Connector

- Standard DB-9 male connector.

### Matching Connector

- Standard DB-9 female connector.

### 7.2.8 Audio Jack (Combo Line Out/Mic In and PC Speaker)

The SYS-427X provides a Combo Line Out / Mic In jack and or use of a PC speaker.

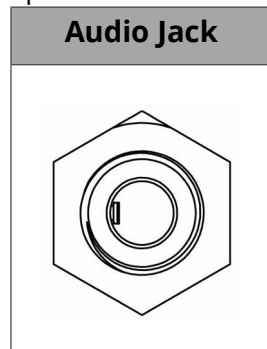

## 7.2.9 GPIO Connector

The SYS-427X provides 8 general purpose input/output connections that are 5-volt tolerant with rising/falling edge event sense interrupt generation.

### Layout and Pin Reference

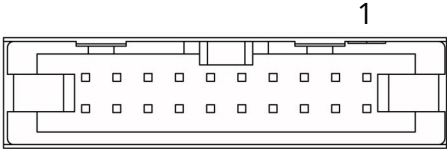
| GPIO Connector   |               |     |              |
|--|---------------|-----|--------------|
|  |               |     |              |
| Pin  | Name          | Pin | Name         |
| 1  | VIN           | 2   | GND          |
| 3  | VIN           | 4   | GND          |
| 5  | VIN           | 6   | GND          |
| 7  | VIN           | 8   | GND          |
| 9  | VIN           | 10  | GND          |
| 11   | VIN           | 12  | GND          |
| 13   | V12 RUN       | 14  | GPIO 0       |
| 15   | I2C PM SCL    | 16  | GPIO 1       |
| 17   | I2C PM SDA    | 18  | PMU RSTBTN N |
| 19   | ALL SYS PWRGD | 20  | PMU PWRBTN N |

### Connector

- 3M™ Wiremount Plug 20-Pin With Threaded Mounting Flanges, Pitch 2.54mm

Part number: 4620-7005

### Matching Connector

- 3M™ Wiremount Plug 20-Pin, Pitch 2.5mm  
Part number: 8520-4500XL or 9120-4500XL

### 7.2.10 J20 - Input Power Header

Use this connection to supply power to the SYS-427X. This computer supports a wide range DC input power from 10 V to 50 V.

#### Layout and Pin Reference

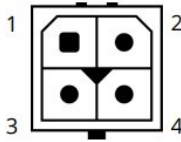
| Pin  | Name             | Pin | Name             |
|--|------------------|-----|------------------|
|  |                  |     |                  |
| 1  | Voltage In (VIN) | 2   | Voltage In (VIN) |
| 3  | Ground (GND)     | 4   | Ground (GND)     |

#### Connector

- Molex Micro-Fit 3.0 vertical header  
Part Number: 43045-0418

#### Matching Connector

- Molex Micro-Fit 3.0 receptacle housing  
Part Number: 43025-0400

### 7.2.11 J12 - Power Module Header (Internal)

This connection accepts WINSYSTEMS power modules providing additional power options such as PoE PD, and UPS backup.

NOTE J12 is used to power the power adapter board in the SYS-427X. Power Module part number is (ADP-PS-433). For alternative front panel input/output options such as analog to digital signals, COM ports, or GPIO, contact a WINSYSTEMS Applications Engineer at +1-817-274-7553.

#### Layout and Pin Reference

| Diagram | Pin | Name          | Pin | Name         |
|---------|-----|---------------|-----|--------------|
|         | 1   | VIN           | 2   | GND          |
|         | 3   | VIN           | 4   | GND          |
|         | 5   | VIN           | 6   | GND          |
|         | 7   | VIN           | 8   | GND          |
|         | 9   | VIN           | 10  | GND          |
|         | 11  | VIN           | 12  | GND          |
|         | 13  | V12_RUN       | 14  | PM_GPIO0     |
|         | 15  | I2C_PM_SCL    | 16  | PM_GPIO1     |
|         | 17  | I2C_PM_SDA    | 18  | PMU_RSTBTN_N |
|         | 19  | ALL_SYS_PWRGD | 20  | PM_PWRBTN_N  |

#### Connector

- Samtec SQW series 2.00 mm rugged sockets  
Part Number: SQW-110-01-F-D-VS-A-K-TR

#### Matching Connector

- Samtec TW series 2.00 mm flex stack  
Part Number: TW-10-03-F-D-280-SM-A

### 7.2.12 J8 - Battery Header (Internal)

An battery connected to the SYS-427X provides standby power for the real-time clock.

#### Layout and Pin Reference

| Pin   | Name |
|---|------|
|  |      |
| 1   | VBAT |
| 2   | GND  |

#### Connector

- Hirose DF13 series 1.25 mm 2-pin  
Part Number: DF13C-2P-1.25V (51)

#### Matching Connector

- Hirose DF13C 1.25 mm 2-pin  
Part Number: DF13C-2S-1.25C

### 7.2.13 J7 - SATA Power Header (Internal)

Power is supplied to the SATA device via the connector at J7.

#### Layout and Pin Reference

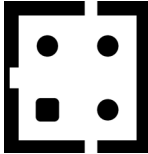
| Pin  | Name    | Pin | Name   |
|--|---------|-----|--------|
|  |         |     |        |
| 1  | +12V SB | 2   | +5V SB |
| 3  | GND     | 4   | GND    |

#### Connector

- Hirose DF11 series 2.00 mm dual-row 4-pin  
Part Number: DF11C-4DP-2V(57)

#### Matching Connector

- Hirose DF11 series 2.00 mm crimping socket 4-pin  
Part Number: DF11-4S-2C

### 7.2.14 J13 - Fan Header (Internal)

#### Layout and Pin Reference

| Pin   | Name    |
|---|---------|
|  |         |
| 1   | TACH_EC |
| 2   | +12 VDC |
| 3   | GND     |

#### Connector

- Hirose DF13 series 1.25 mm 3-pin  
Part Number: DF13C-3P-1.25V (51)

#### Matching Connector

- Hirose DF13C 1.25 mm 3-pin  
Part Number: DF13C-2S-1.25C

### 7.2.15 J6 - LVDS Data and Backlight Header (Internal)

The SYS-427X supports single channel LVDS flat panel displays with resolutions up to 1440 x 1080 or 1600 x 900 at 24 bpp.

The LVDS output signals are odd bus, differential signals to the LVDS receiver. Each LVDS **P** output makes a differential pair with LVDS **N**.

#### Layout and Pin Reference

| Pin | Name       | Description                      | Pin | Name     | Description                         |
|-----|------------|----------------------------------|-----|----------|-------------------------------------|
|     |            |                                  |     |          |                                     |
| 1   | LVDSAO_P   | Channel A - Positive LVDS Output | 2   | LVDSBO_P | Channel B - Positive LVDS Output    |
| 3   | LVDSAO_N   | Channel A - Negative LVDS Output | 4   | LVDSBO_N | Channel B - Negative LVDS Output    |
| 5   | GND        | Ground                           | 6   | GND      | Ground                              |
| 7   | LVDSO_P    | Channel C - Positive LVDS Output | 8   | LVDSO_P  | Channel D - Positive LVDS Output    |
| 9   | LVDSO_N    | Channel C - Negative LVDS Output | 10  | LVDSO_N  | Channel D - Negative LVDS Output    |
| 11  | GND        | Ground                           | 12  | GND      | Ground                              |
| 13  | LVDSCKO_P  | Positive LVDS Clock Output       | 14  | DDC_SCL  | Open-drain DDC Data I/O             |
| 15  | LVDSCKO_N  | Negative LVDS Clock Output       | 16  | DDC_SDA  | Open-drain DDC Clock I/O            |
| 17  | GND        | Ground                           | 18  | GND      | Ground                              |
| 19  | I2C_TC_SCL | I2C Touch Control Clock          | 20  | VCC_LVDS | +3.3 VDC                            |
| 21  | I2C_TC_SDA | I2C Touch Control Data           | 22  | VCC_LVDS | +3.3 VDC                            |
| 23  | GND        | Ground                           | 24  | GND      | Ground                              |
| 25  | BKLT_PWM   | Backlight PWM brightness control | 26  | BKLT_PWR | Backlight Power (+5 VDC or +12 VDC) |
| 27  | BKLT_EN    | Backlight Enable                 | 28  | BKLT_PWR | Backlight Power (+5 VDC or +12 VDC) |
| 29  | SEL68      | Select 8/6-bit                   | 30  | BKLT_PWR | Backlight Power (+5 VDC or +12 VDC) |

**Connector**

- Hirose DF13 Series 1.25 mm double row 30-pin  
Part Number: DF13EA-30DP-1.25V(51)

**Matching Connectors**

- Hirose DF13C 1.25 mm double row 30-pin  
Part Number: DF13-30DS-1.25C

**7.2.16 J504 - USB Touchscreen Header (Internal)**

J504 provides plug-and-play support for a USB touchscreen. Aside from a simpler and faster interface, it also provides power within the USB cable, eliminating the need for a separate, dedicated cable to power the touchscreen.

**Layout and Pin Reference**

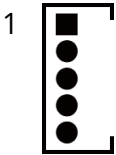
| Pin  | Name   |
|--|--------|
|  |        |
| 1  | GND    |
| 2  | +5V SB |
| 3  | DATA+  |
| 4  | DATA-  |
| 5  | GND    |

**Connector**

- Molex 1.25 mm PicoBlade  
Part Number: 53398-0571

**Matching Connector**

- Molex 1.25 mm PicoBlade housing  
Part Number: 51021-0500

### 7.2.17 SP500 - Speaker (Internal)

An on-board speaker, SP500, is available for sound generation. The BIOS activates the speaker to beep during POST failure. Each error has its own unique beep code. Refer to *BIOS Status and Errors* in the supplemental BIOS Manual located under documentation on the WINSYSTEMS SYS-427X webpage.

### 7.2.18 J2 - HD Audio Header (Internal)

The HD audio header supports sample rates ranging from 44.1 to 192 kHz. The left and right front audio channels provide concurrent independent stereo sound output (multiple streaming).

NOTE J2 is used to supply Line Out/Mic In to the front I/O panel. For alternative front panel input/output options such as analog to digital signals, COM ports, or GPIO, contact a WINSYSTEMS Applications Engineer at +1-817-274-7553.

#### Layout and Pin Reference

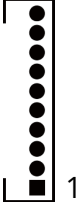
| Pin  | Name    |
|--|---------|
|  |         |
| 1  | HDA GND |
| 2  | MIC L   |
| 3  | MIC R   |
| 4  | HDA GND |
| 5  | LINE L  |
| 6  | LINE R  |
| 7  | HDA GND |
| 8  | FRONT L |
| 9  | FRONT R |
| 10   | HDA GND |

#### Connector

- Hirose DF13 series 1.25 mm 10-pin  
Part Number: DF13C-10P-1.25V (51)

#### Matching Connector

- Hirose DF13C 1.25 mm 10-pin  
Part Number: DF13C-10S-1.25C

## 7.2.19 J1 - Legacy RS232 Header (Internal)

The legacy RS232 header provides port IO addresses defined in the original PC specification. The legacy UART allows software originally designed for older PCs to function on the SYS-427X.

NOTE J1 is used to run the IO address lines to COM3 connector located on the front I/O panel. For alternative front panel input/output options such as analog to digital signals, COM ports, or GPIO, contact a WINSYSTEMS Applications Engineer at +1-817-274-7553.

### Layout and Pin Reference

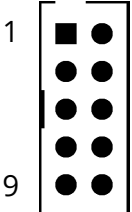
| Diagram   | Pin | Name | Pin | Name |
|---|-----|------|-----|------|
|  | 1   | DCD  | 2   | DSR  |
|   | 3   | RXD  | 4   | RTS  |
|   | 5   | TXD  | 6   | CTS  |
|   | 7   | DTR  | 8   | RI   |
|   | 9   | GND  | 10  | NC   |

### Connector

- Molex Milli-Grid header, shrouded with locking window  
Part Number: 87832-1006

### Matching Connectors

- Molex Milli-Grid receptacles (with locking ramp)  
Part Number: 51110-1060



### Warning

Do not use receptacle with center polarization key.

### 7.2.20 J4 - Serial Ports (RS232/422/485) Header (Internal)

NOTE J4 is used to run the IO address lines to COM1 and COM2 connectors located on the front I/O panel. For alternative front panel input/output options such as analog to digital signals, COM ports, or GPIO, contact a WINSYSTEMS Applications Engineer at +1-817-274-7553

#### Layout and Pin Reference

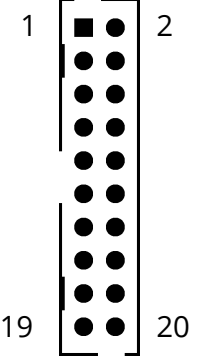
| Pin   | Name             | Pin | Name             |
|---|------------------|-----|------------------|
|  |                  |     |                  |
| 1   | NC               | 2   | NC               |
| 3   | RXD1/ RX+        | 4   | RTS1/ TX+/ TXRX+ |
| 5   | TXD1/ TX-/ TXRX- | 6   | CTS1/ RX-        |
| 7   | NC               | 8   | NC               |
| 9   | GND              | 10  | NC               |
| 11  | NC               | 12  | NC               |
| 13  | RXD2/ RX+        | 14  | RTS2/ TX+/ TXRX+ |
| 15  | TXD2/ TX-/ TXRX- | 16  | CTS2/ RX-        |
| 17  | NC               | 18  | NC               |
| 19  | GND              | 20  | NC               |

#### Connector

- Molex Milli-Grid header, shrouded with center polarization slot and locking windows

Part Number: 87832-2020

#### Matching Connectors

- Molex Milli-Grid receptacles with center polarization key and locking ramps

Part Number: 51110-2051

### 7.2.21 J10/J11 - USB 2.0 Port 2x Headers (Internal)

J10 and J11 provide four USB 2.0 ports supplying 500 mA maximum continuous current per channel.

NOTE J11 is used to deliver two USB 2.0 ports to the front panel I/O Type A connectors via the ADP-USB-445. J10 is not accessible when using the dual USB Type A Flex-IO Module (ADP-USB-445). For alternative front panel input/output options such as analog to digital signals, COM ports, or GPIO, contact a WINSYSTEMS Applications Engineer at +1-817-274-7553.

#### Layout and Pin Reference

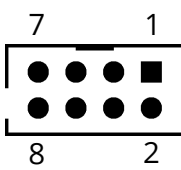
| Pin   | Name     | Pin | Name     |
|---|----------|-----|----------|
|  |          |     |          |
| 1   | USB1 VCC | 2   | USB2 VCC |
| 3   | DATA1-   | 4   | DATA2-   |
| 5   | DATA1+   | 6   | DATA2+   |
| 7   | GND      | 8   | GND      |

#### Connector

- Molex Milli-Grid header, shrouded with locking window  
Part Number: 87832-0806

#### Matching Connectors

- Molex Milli-Grid receptacles (with locking ramp)  
Part Number: 51110-0860



#### Warning

Do not use receptacle with center polarization key.

### 7.2.22 J3 - Serial SATA 6Gbps Connector (Internal)

J3 provides a serial SATA 6 Gbps 7-pin connector for interfacing with hard disk drives and solid state disk drives.

#### Connectors

- Standard 7-pin serial ATA connector

#### Matching Connector

- Standard serial ATA 6 Gbps signal cables

### 7.2.23 J500 - RAM Connector (Internal)

Connector J500 is a DDR3L, 204-pin, SODIMM socket, accommodating a maximum of 8 GB error-correcting code (ECC) RAM.

**Warning**

Do not install non-ECC RAM in this SODIMM socket.

### 7.2.24 J5 - GPIO General-Purpose Input/Output Header (Internal)

The SYS-427X supplies eight 5V-tolerant GPIO lines with rising/falling edge event sense interrupt generation.

J5 is used to deliver GPIO lines to the GPIO connector located on the front I/O panel.

NOTE For alternative front panel input/output options such as analog to digital signals, COM ports, or GPIO, contact a WINSYSTEMS Applications Engineer at +1-817-274-7553.

#### Layout and Pin Reference

| Pin | Name   | Pin | Name |
|-----|--------|-----|------|
|     |        |     |      |
| 1   | GPIO_0 | 2   | GND  |
| 3   | GPIO_1 | 4   | GND  |
| 5   | GPIO_2 | 6   | GND  |
| 7   | GPIO_3 | 8   | GND  |
| 9   | GPIO_4 | 10  | GND  |
| 11  | GPIO_5 | 12  | GND  |
| 13  | GPIO_6 | 14  | GND  |
| 15  | GPIO_7 | 16  | GND  |
| 17  | +5V    | 18  | GND  |
| 19  | +5V    | 20  | GND  |

#### Connector

- Hirose DF13 series 1.25 mm double row 30-pin  
Part Number: DF13EA-20DP-1.25V(51)

#### Cables

- Hirose DF13C 1.25 mm double row 20-pin  
Part Number: DF13-20DS-1.25C

## 7.2.25 J14 - Analog Inputs (Analog to Digital) Header (Internal)

### Layout and Pin Reference

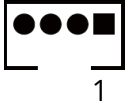
| Pin   | Name    |
|---|---------|
|  |         |
| 1   | ADC_CH0 |
| 2   | GND     |
| 3   | ADC_CH1 |
| 4   | GND     |

### Connector

- Hirose DF13 series 1.25 mm 4-pin  
Part Number: DF13C-4P-1.25V (51)

### Matching Connector

- Hirose DF13C 1.25 mm 4-pin  
Part Number: DF13C-4S-1.25C

## 7.2.26 J502 - Modular IO80 (Internal)

### Layout and Pin Reference

| Pin | Name         | Pin | Name             | Pin | Name                 | Pin | Name                |
|-----|--------------|-----|------------------|-----|----------------------|-----|---------------------|
|     |              |     |                  |     |                      |     |                     |
| 1   | PCIE4_TX+    | 2   | USB3_TX+         | 41  | GND                  | 42  | GND                 |
| 3   | PCIE4_TX-    | 4   | USB3_TX-         | 43  | RESERVED             | 44  | LPC_CLK (3.3V)      |
| 5   | GND          | 6   | GND              | 45  | RESERVED             | 46  | LPC_FRAME (3.3V)    |
| 7   | PCIE4_RX+    | 8   | USB3_RX+         | 47  | GND                  | 48  | LPC_AD3 (3.3V)      |
| 9   | PCIE4_RX-    | 10  | USB3_RX-         | 49  | RESERVED             | 50  | LPC_AD2 (3.3V)      |
| 11  | GND          | 12  | GND              | 51  | RESERVED             | 52  | LPC_AD1 (3.3V)      |
| 13  | PCIE5_TX+    | 14  | USB2_D0+         | 53  | GND                  | 54  | LPC_AD0 (3.3V)      |
| 15  | PCIE5_TX-    | 16  | USB2_D0-         | 55  | RESERVED             | 56  | BUF_PLTRST_N (3.3V) |
| 17  | GND          | 18  | GND              | 57  | RESERVED             | 58  | LPC_SERIRQ (3.3V)   |
| 19  | PCIE5_RX+    | 20  | USB2_D1+         | 59  | GND                  | 60  | GND                 |
| 21  | PCIE5_RX-    | 22  | USB2_D1-         | 61  | ISH_GPIO[11] (1.8V)  | 62  | I2C1_SCL (1.8V)     |
| 23  | GND          | 24  | GND              | 63  | ISH_GPIO[12] (1.8V)  | 64  | I2C1_SDA (1.8V)     |
| 25  | PCIE_REFCLK+ | 26  | USB_OC#          | 65  | ISH_GPIO[13] (1.8V)  | 66  | ISH_GPIO[10] (1.8V) |
| 27  | PCIE_REFCLK- | 28  | USB_OC#          | 67  | GND                  | 68  | GND                 |
| 29  | GND          | 30  | GND              | 69  | LINE_OUT_L           | 70  | HDA_GND             |
| 31  | RESERVED     | 32  | SPI1_CLK (1.8V)  | 71  | LINE_OUT_R           | 72  | HDA_GND             |
| 33  | RESERVED     | 34  | SPI1_MOSI (1.8V) | 73  | BUF_PLTRST_N (3.3V)  | 74  | PCIE_WAKE_N (3.3V)  |
| 35  | GND          | 36  | SPI1_MISO (1.8V) | 75  | ALL_SYS_PWRGD (3.3V) | 76  | PMU_SLP_S3 (3.3V)   |
| 37  | RESERVED     | 38  | SPI1_CS0 (1.8V)  | 77  | 12VA                 | 78  | V5A                 |
| 39  | RESERVED     | 40  | SPI1_CS1 (1.8V)  | 79  | 12VA                 | 80  | V5A                 |

#### Connector

- Amphenol BergStak Mezzanine connector 0.8 mm 80-pin

Part Number: 61083-082602LF

#### Matching Connector

- Amphenol BergStak receptacle 0.8 mm 80-pin

Part Number: 61082-081400LF

For additional enclosure expansion options, contact a WINSYSTEMS at +1-817-274-7553.

### 7.2.27 J503 - M.2 Socket 1, with E key (Internal)

The M.2 expansion socket typically provides support for E key, type 2230 form factor WiFi and Bluetooth modules.

This connector supports PCIe Gen2 x1, SDIO, USB 2.0, UART, and I2C interfaces.

### 7.2.28 J501 - Mini PCIe (with mSATA Support) (Internal)

The SYS-427X Mini PCIe socket supports a variety of peripherals as available in this format. Though the sockets support other devices, they are most often used to add mSATA SSD, wireless Ethernet cards from Broadcom, Foxconn (Atheros), or others. This Mini PCIe socket supports SATA, PCIe, and USB.

## 7.3 Jumpers

### 7.3.1 JP1 - Board Configuration Jumpers (Internal)

Jumping pins 1-2 enable you to reset the BIOS CMOS settings to factory defaults. The BIOS reads this pin during system boot and forces the settings to reset if the pin is at ground.

To reset the BIOS CMOS parameters:

1. Remove power from the SYS-427X.
2. Place a jumper across 1-2.
3. Apply power to the computer, and let it boot into the BIOS.
4. Power off the SYS-427X, and remove the jumper at 1-2.

Jumping pins 3-4 configures LVDS output as 24-bit. Removing the jumper configures the output as 18-bit.

#### Layout and Pin Reference

| Diagram | Selection                      | Jumper Positions |
|---------|--------------------------------|------------------|
|         | Backlight Power = 12V          | 11-12 (Default)  |
|         | Backlight Power = 5V           | 9-11             |
|         | Backlight Enable = Active Low  | 7-8              |
|         | Backlight Enable = Active High | 5-7 (Default)    |
|         | LVDS 18-bit/24-bit Select      | 3-4 (Default)    |
|         | Load BIOS Defaults             | 1-2              |

## 7.4 LED Indicators

### LED Reference

| LED       | Description                    | Color        |
|-----------|--------------------------------|--------------|
| D6        | +12 VDC                        | Red          |
| D7        | +3.3 VDC                       | Yellow       |
| D8        | +3.3 VSB                       | Green        |
| D510      | EC_LED                         | Green        |
| ETH1_LED1 | LINK1000=GREEN, LINK100=YELLOW | Green/yellow |
| ETH1_LED2 | LINK=SOLID, ACTIVITY=BLINKING  | Green        |
| ETH2_LED2 | LINK1000=GREEN, LINK100=YELLOW | Green/yellow |
| ETH2_LED1 | LINK=SOLID, ACTIVITY=BLINKING  | Green        |

If the EC\_LED is toggling, the chip is in full on running state. If the EC\_LED is not toggling, then the chip has entered the programmed sleep state.

## 7.5 Watchdog Timer (WDT)

### 7.5.1 WDT Register Usage

The Watchdog Timer (WDT) implemented in the SYS-427X's embedded controller (EC) can be used to reset the system if a lock-up prevents a software task from periodically resetting the watchdog timer. The WDT is controlled through a set of virtual registers that are exposed to Apollo Lake applications by the EC on the SYS-427X. The WDT can be programmed to count in either seconds or minutes; it has a minimum granularity of 1 second, and a maximum granularity of 255 minutes.

## 7.6 Real-time Clock/Calendar

A real-time clock is used as the AT-compatible clock/calendar. It supports a number of features including periodic and alarm interrupt capabilities. In addition to the time and date-keeping functions, the system configuration is kept in CMOS RAM contained within the clock section. A battery must be enabled for the real-time clock to retain time and date during a power down.

WINSYSTEMS has software available for manipulating the CMOS RTC from a high-level application.

## 7.7 System Management Software

The system management software for the SYS-427X consists of a set of library functions and example applications that demonstrate the functionality of the system management software. The software is available for both Windows 10 and Ubuntu Linux.

The system management software is custom software designed to use the built-in functionality of the SYS-427X's embedded controller (MicroChip MEC1418) to perform system management tasks such as reporting of board voltages (3.3V, 5V, 12V,  $V_{ddq}$ ,  $V_{core}$ ,  $V_{bat}$ , and the pair of user ADC inputs), the control of the system fan, reporting of the ambient temperature and setting of temperature sensor thresholds. Additional functionality allows applications to determine the version of the EC firmware, report the boot image used when the system started, and allow the EC to update its own firmware image. The EC contains a pair of identical images for redundancy and rolls over to a correct image if the first image is compromised.

## 8. BIOS Functionality

The SYS-427X BIOS settings and option descriptions can be found in our supplemental SYS-427X BIOS Manual.

### 8.1 Software Description

This section provides details on the AMI BIOS components to be used in the implementation of the SYS-427X BIOS firmware.

#### 8.1.1 Software Design Specification: UEFI Operating System Support

The BIOS supports the booting of the following UEFI compliant operating systems:

- Windows 10 x64, IoT Core, and Professional
- Linux x64
- Most x86 operating systems

#### 8.1.2 Software Design Specification: Legacy Operating System Support

The BIOS supports the booting of the following legacy OS capabilities:

- MS-DOS 6
- Compatibility support module (CSM)
- Legacy boot support
- Legacy option ROM support

#### 8.1.3 Software Design Specification: Boot Device Configuration

The BIOS supports booting an OS from the following devices:

- USB mass storage device
- mSATA MiniCard
- Serial ATA (SATA) device
- eMMC
- Network boot - PXE

### 8.1.4 Software Design Specification: BIOS Update Mechanisms

The BIOS supports the following update mechanisms:

- BIOS update with UEFI shell
- Software utilities
- Flash recovery via USB mass storage device
- Flash recovery via eMMC device
- Embedded controller (EC) firmware update with UEFI shell

### 8.1.5 Software Design Requirements: BIOS Components

The BIOS includes the following components:

- **Advanced Host Controller Interface (AHCI) support:** Provides SATA host controller functionality.
- **Display switching in setup:** Implements display switching using the UEFI GOP driver under the SETUP environment.
- **Boot order:** Generates the default boot order on the platform's first boot.
- **Boot/resume from S4 device:** Allows the platform to boot from the last S4 hibernated device, disregarding the current boot priority.
- **Cryptographic support:** Provides cryptographic related libraries, PPI, and UEFI protocols for security modules (secure FW update, secure boot, etc.)
- **Source level support:** Provides source level debug functionality for the BIOS project.
- **Fastboot:** Provides optimization of the boot time.
- **Fixed boot order:** Provides infrastructure that allows custom handling of available boot options to meet specific customer needs. Custom boot behavior may include different requests, such as always boot from specific device, default support of various kinds of grouping of boot devices.
- **Generic error logging:** Provides support for logging POST and runtime errors to the GPNV area.
- **Keyboard controller emulation** for USB keyboard/mouse.
- **Physical RAM testing:** Supports testing of physical RAM present in the system.
- RTC registration and ability to handle wakeup from S5 sleep state.

- **Secure boot support:** provides support and functionality to conform with UEFI 2.3.1 secure boot requirements and includes the following components:
  - Extended functionality of EFI NVRAM driver with support for authenticated EFI variables.
  - EFI image authentication module that installs EFI security architecture protocol with image authentication and image execution policy.
  - Secure boot variable (PK, KEK, db, and dbx) provisioning.
- Support for the booting to the built in UEFI shell.

## 8.2 BIOS Update with UEFI Shell

### 8.2.1 Scope

The Unified Extensible Firmware Interface (EFI or UEFI for short) is a model for the interface between operating systems and firmware. It provides a standard environment for booting an operating system and running pre-boot applications.

An optional feature of a UEFI implementation is the ability to boot the system to a built-in shell. The UEFI shell provides a command prompt and a rich set of commands that extend and enhance the capability of the UEFI BIOS.

This section describes the process for updating the SYS-427X BIOS firmware image using the built-in UEFI shell.

### 8.2.2 Process

1. Insert a USB flash drive containing the BIOS update program into a USB socket on the SYS-427X platform.
2. Turn on the SYS-427X and press the **ESC** or **DEL** key during the boot process, which starts the BIOS setup utility.
3. In the BIOS setup utility, use the cursor keys to highlight the **Save & Exit** menu option.
4. Use the cursor keys to select **UEFI: Built-In EFI Shell** from the list of boot devices displayed under the **Boot Override** section.
5. Press **Enter**.

The SYS-427X executes the built-in UEFI shell, and displays a list of attached storage devices. The USB flash drive shows up in the list; depending on other boot devices attached, it may be listed as **fs0**, **fs1**, etc.

6. From the UEFI shell command prompt, enter the following command where `N` is the number of the fs device representing the USB flash drive:

```
fsN:
```

Example: `fs1:`

The shell prompt changes to indicate that device `fsN` is now the active storage device, e.g., `fs1:`

7. Execute the following command:

```
ls
```

The output of the `ls` command is similar to the display listing available with the Linux or MS-DOS list directory command. If the correct storage device was selected in step 6 above, the `ls` command should show the BIOS update program in the directory listing obtained with the `ls` command.

8. Assuming the BIOS update program is named `Update.efi`, enter the following command at the shell command prompt:

```
Update.efi
```

The BIOS update program begins executing.

9. When the update program completes, power cycle the platform to force the new BIOS image to load and execute.
10. Verify that the BIOS update was successful by comparing the displayed BIOS version with the version specified in the BIOS update notification.

## 8.3 Embedded Controller (EC) Update with UEFI Shell

### 8.3.1 Scope

The Unified Extensible Firmware Interface (EFI or UEFI for short) is a model for the interface between operating systems and firmware. It provides a standard environment for booting an operating system and running pre-boot applications.

An optional feature of a UEFI implementation is the ability to boot the system to a built-in shell. The UEFI shell provides a command prompt and a rich set of commands that extend and enhance the capability of the UEFI BIOS.

This section describes the process for updating the SYS-427X Embedded Controller (EC) image using the built-in UEFI shell.

### 8.3.2 Process

1. Insert a USB flash drive containing the EC update program into a USB socket on the SYS-427X platform.
2. Turn on the SYS-427X and press the **ESC** or **DEL** key during the boot process, which starts the BIOS setup utility.
3. In the BIOS setup utility, use the cursor keys to highlight the **Save & Exit** menu option.
4. Use the cursor keys to select **UEFI: Built-In EFI Shell** from the list of boot devices displayed under the **Boot Override** section.
5. Press **Enter**.

The SYS-427X executes the built-in UEFI shell, and displays a list of attached storage devices. The USB flash drive shows up in the list; depending on other boot devices attached, it may be listed as **fs0**, **fs1**, etc.

6. From the UEFI shell command prompt, enter the following command where **N** is the number of the fs device representing the USB flash drive:

```
fsN:
```

Example: `fs1:`

The shell prompt changes to indicate that device fsN is now the active storage device, e.g., `fs1:`

7. Execute the following command:

```
ls
```

The output of the `ls` command is similar to the display listing available with the Linux or MS-DOS list directory command. If the correct storage device was selected in step 6 above, the `ls` command should show the EC update program in the directory listing obtained with the `ls` command.

8. Assuming the EC update program is named `Update.efi`, enter the following command at the shell command prompt:

```
Update.efi
```

The EC update program begins executing.

9. When the update program completes, power cycle the platform to force the new EC image to load and execute.
10. Verify that the EC update was successful by comparing the displayed EC version in the BIOS with the version specified in the EC update notification.

## 9. Software Drivers

Go to <https://www.winsystems.com/> for information on available software drivers.

## 10. Options

### 10.1 Standard Model

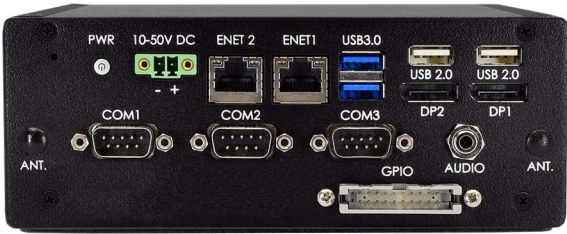
| Standard Model  |   |
|---|---|
| Part Number: SYS-427X-0   | Description   |
|  <p>The image shows the rear panel of the SYS-427X-0 Standard Model. It features a variety of ports including a power jack (PWR), a 10-50V DC power input, two Ethernet ports (ENET 2 and ENET 1), a USB 3.0 port, two USB 2.0 ports, two DisplayPort ports (DP2 and DP1), three COM ports (COM1, COM2, and COM3), a GPIO port, an audio jack (AUDIO), and two antenna ports (ANT.).</p> | <p>This is the standard SYS-427X model, as represented in the main portion of this product manual. It does not include either CAN bus nor WiFi.</p> |

## 10.2 Option 1

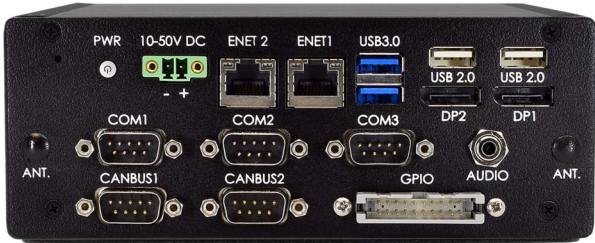
| Option 1 Model   |             |  |             |
|--|-------------|--|-------------|
| Part Number: SYS-427X-1  |             | Description  |             |
| <b>Option 1</b>  |             | 2x Isolated CAN Bus 2.0B/J1939/CAN Open  |             |
|   |             | <p>The SYS-427X-1 Controller Area Network bus (CAN bus) model comes with a modified front plate, two external CAN bus DB9 connectors, and the Innodisk EMUC-B2S3 mPCIe to dual isolated CAN 2.0B/J1939/CANopen module. The CAN bus module uses the MiniPCIe socket, so this socket is not available for other use.</p> |             |
| CAN bus features include:  |             |  |             |
| <ul style="list-style-type: none"> <li>Compliant with ISO 1189802</li> <li>Supports baud rates of 100/125/250/500 (default)/800/1000K</li> <li>Supports CAN message acceptance filter, listen-only mode</li> <li>Keeps configuration after hardware reboot</li> <li>Up to 7,800 frames/sec (receiving at 1Mbps, EID, 8byte data)</li> <li>Complies with EN61000-4-5 2.5kV Surge protection</li> <li>Complies with IEC 60950-1:2005 + A1: 2009 + A2:2013 2.5kV HiPOT protection</li> <li>Compliant with EN61000-4-2 (ESD) Air-15kV, Contact-8kV</li> <li>Industrial temperature (-40°C to +85°C) support</li> </ul> |             |  |             |
| Specifications   |             |  |             |
| <ul style="list-style-type: none"> <li>Input I/F: USB 2.0 High Speed (480Mbps)</li> <li>Output I/F: CANbus 2.0B</li> <li>Output Connector 2 x DB-9</li> <li>Power Consumption: MAX : 2.115W (5V, 423mA; 3.3V, 641mA)</li> <li>Environment: Vibration: 5G @7~2000Hz, Shock: 50G @ 0.5ms</li> </ul>  |             |  |             |
| Usage:   |             |  |             |
| <ul style="list-style-type: none"> <li>CAN bus drivers are included in the WINSYSTEMS OS for Windows and Ubuntu Linux for this device if you purchase it with an OS. If you purchase the device without an OS, you will need to download the CAN bus driver from: <a href="https://www.innodisk.com/">https://www.innodisk.com/</a> and search for EMUC-B2S3.</li> </ul>   |             |  |             |
| CAN bus DB9 Connector Pinouts:   |             |  |             |
| PIN  | Description | PIN  | Description |
| 1  | NC          | 2  | CAN-L       |
| 3  | GND         | 4  | NC          |
| 5  | NC          | 6  | NC          |
| 7  | CAN-H       | 8  | NC          |
| 9  | NC          |  |             |

## 10.3 Option 2



| Option 2 Model  |   |
|---|---|
| Part Number: SYS-427X-2   | Description   |
| <b>Option 2</b>   | WiFi 6 Connectivity (Dual Antennas)   |
|    | <p>The SYS-427X-2 WiFi 6 model provides 2nd Generation Intel Wi-Fi 6 Wireless with Extended Wi-Fi 6E (6GHz Band) support. It comes with the standard front plate, the Intel® WiFi6E AX210 M.2 2230 A+E-KEY Module, two antenna connectors, and two antennas. This model uses the M.2 socket, so this socket is not available for other use.</p> |
| <b>WiFi features include:</b>   |   |
| <ul style="list-style-type: none"> <li>• Supports Wi-Fi 6E with Wi-Fi 6 Release 2 features</li> <li>• Supports dual-stream Wi-Fi in the 2.4GHz, 5GHz and 6GHz bands</li> <li>• Backwards compatible with Wi-Fi 4, 5, and 6</li> <li>• Supports Bluetooth® 5.4</li> <li>• Support for Wi-Fi network and Bluetooth® Low Energy HID connectivity in the platform's UEFI environment during its boot stage. This enables use cases like OS recovery over Wi-Fi and BTLE-based keyboard and mouse connectivity in this pre-boot environment.</li> </ul>  |   |
| <b>Specifications</b>   |   |
| <ul style="list-style-type: none"> <li>• Wi-Fi 6E (6GHz), 2x2, Bluetooth® 5.4, M.2 2230</li> <li>• Wi-Fi Alliance: Wi-Fi CERTIFIED 6 with Wi-Fi 6E, Wi-Fi CERTIFIED a/b/g/n/ac, WMM, WMM-Power Save, WPA3, PMF, Wi-Fi Direct, Wi-Fi Agile Multiband, Wi-Fi Location R2 HW readiness</li> <li>• IEEE WLAN Standard: IEEE 802.11-2020 and select amendments, IEEE 802.11a, b, d, e, g, h, l, k, n, r, u, v, w, ac, ax; Fine Timing Measurement based on 802.11-2016, 80211az HW readiness</li> <li>• Bluetooth® 5.4</li> <li>• Security Methods: WPA3 personal and enterprise security including WPA2 transition mode</li> <li>• Encryption: 128-bit AES-CCMP, 256-bit AES-GCMP</li> <li>• Authentication Protocols: 802.1X EAP-TLS, EAP-TTLS/MSCHAPv2, PEAPv0 -MSCHAPv2 (EAP-SIM, EAP-AKA)</li> <li>• Operating temperature: 0°C to +80°C</li> <li>• Humidity Non-Operating: 50% to 90% RH non-condensing at temperatures of 25°C to 35°C</li> <li>• Certifications: UL, C-UL, CB (IEC 62368-1)</li> </ul> |   |
| <b>Usage:</b>   |   |
| <ul style="list-style-type: none"> <li>• WiFi can be enabled/disabled and WiFi connection selected from the standard computer settings as for a typical computer.</li> <li>• The WiFi drivers are included in the WINSYSTEMS OS for Windows and Ubuntu Linux for this device if you purchase it with an OS. If you purchase the device without an OS, you will need to download the drivers from <a href="https://www.intel.com">https://www.intel.com</a> and search for AX210. Driver links should appear in the left menu of the product page.</li> </ul>  |   |

## 10.4 Option 3

| Option 3 Model  |   |
|---|---|
| Part Number: SYS-427X-3   | Description   |
| <b>Option 3</b>   | 2x Isolated CAN Bus 2.0B/J1939/CAN Open + WiFi 6 Connectivity (Dual Antennas)   |
|  | <p>The CAN bus + Wi-Fi 6 model comes with a modified outer case and all of the added components and specifications for Option 1 and Option 2 models. This model uses both the mPCIe and M.2 sockets, so these sockets are not available for other uses. Refer to the CAN bus and WiFi models above for related details.</p> |

# 11. Accessories

**NOTE** WINSYSTEMS accessories for the SYS-427X include the following. Ordered accessories come installed on your system.

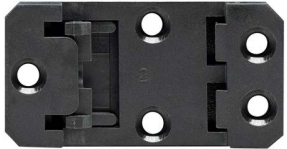
| Item  | Part Number     | Description  | Product View   |
|---|-----------------|--|--|
| Battery   | BAT-LPC-BR2330  | 3V 255 mA Coin Type Lithium off-board Battery, -40°C to +85°C, 1.25 mm 2-pin.<br>Designed to provide standby power for real time clock and CMOS setup RAM functions.   |   |
| 2.5" SATA SSD                                     |                 | 128 GB to 2 TB industrial SATA SSD, -40°C to +85°C.<br>This uses the internal SATA and SATA power connectors, so this connector would not be available for other uses. |   |
| DIN Rail Mount Kit                                | KIT-MNT-427-DIN | ROHS, Din rail mounting clip. Black, 35MM Width.<br>Includes bracket and screws.   |  |
| <b>NOTE</b> VESA mount would be a custom request. |                 |  |  |

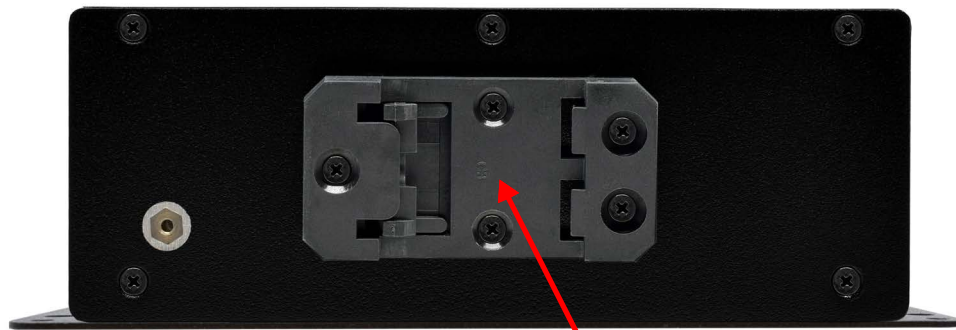

DIN Rail Mount Bracket (optional)

WINSYSTEMS PN: KIT-MNT-427-DIN

## Appendix A. Best Practices

The following paragraphs outline the best practices for operating the SYS-427X in a safe, effective manner, that does not damage the board. Read this section carefully.

### Power Supply



#### **Avoid electrostatic discharge (ESD)**

Only handle the circuit board and other bare electronics when electrostatic discharge (ESD) protection is in place. Having a wrist strap and a fully grounded workstation is the minimum ESD protection required before the ESD seal on the product bag is broken.

#### **Power Supply Budget**

Evaluate your power supply budget. It is usually good practice to budget twice the typical power requirement for all of your devices.

#### **Zero-load Power Supply**

Use a zero-load power supply whenever possible. A zero-load power supply does not require a minimum power load to regulate. If a zero-load power supply is not appropriate for your application, then verify that the single board computer's typical load is not lower than the power supply's minimum load. If the single board computer does not draw enough power to meet the power supply's minimum load, then the power supply does not regulate properly and can cause damage to the SYS-427X.



#### **Use proper power connections (voltage)**

When verifying the voltage, measure it at the power connector on the SYS-427X. Measuring it at the power supply does not account for voltage drop through the wire and connectors.

The SYS-427X requires 10V to 50V to operate. Verify the power connections. Incorrect voltages can cause catastrophic damage.

The SYS-427X has a single power connector on the front IO plate. A single 10V-50V DC input and ground is required to power the SYS-427E.

#### **Power Harness**

Minimize the length of the power harness. This reduces the amount of voltage drop between the power supply and the SYS-427X.

### Gauge Wire

Use the largest gauge wire that you can. Most connector manufacturers have a maximum gauge wire they recommend for their pins.

### Contact Points

WINSYSTEMS boards mostly use connectors with gold finish contacts. Gold finish contacts are used exclusively on high-speed connections. Power and lower speed peripheral connectors may use a tin finish as an alternative contact surface. It is critical that the contact material in the mating connectors is matched properly (gold to gold and tin to tin). Contact areas made with dissimilar metals can cause oxidation/corrosion, resulting in unreliable connections.

### Pin Contacts

Often the pin contacts used in cabling are not given enough attention. The ideal choice for a pin contact would include a design similar to Molex or Trifurcon designs, which provide three distinct points to maximize the contact area and improve connection integrity in high shock and vibration applications.

## Power Down

Make sure that power has been removed from the system before making or breaking any connections.



**Power supply OFF**—Always turn off the power supply before connecting to the I/O Module. Do not hot-plug the SYS-427X on a host platform that is already powered.

**I/O connections OFF**—Turn off all I/O connections before connecting them to the embedded computer modules or any I/O cards. Connecting hot signals can cause damage whether the embedded system is powered or not.

## Conformal Coating

Conformal coating by any source other than WINSYSTEMS voids the product warranty and will not be accepted for repair by WINSYSTEMS. If such a product is sent to WINSYSTEMS for repair, it will be returned at customer expense and no service will be performed. A WINSYSTEMS product conformally coated by WINSYSTEMS will be subject to regular WINSYSTEMS warranty terms and conditions.

## Operations/Product Manuals

Every Winsystems computer system and single board computer has an Operations manual or Product manual.

**Periodic updates**—Operations/product manuals are updated often. Periodically check the WINSYSTEMS website (<https://winsystems.com/product/sys-427x/>) for revisions.

**Check pin-outs**—Always check the pin-out and connector locations in the manual before plugging in a cable. Many I/O modules have identical headers for different functions and plugging a cable into the wrong header can have disastrous results.

**Contact an engineer**—If a diagram or chart in a manual does not seem to match your board, or if you have additional questions, contact a WINSYSTEMS engineer at +1-817-274-7553 or contact by email at <https://winsystems.com/support/>.

# Appendix B. Mechanical Drawings

## SYS-427X Mechanical Drawings

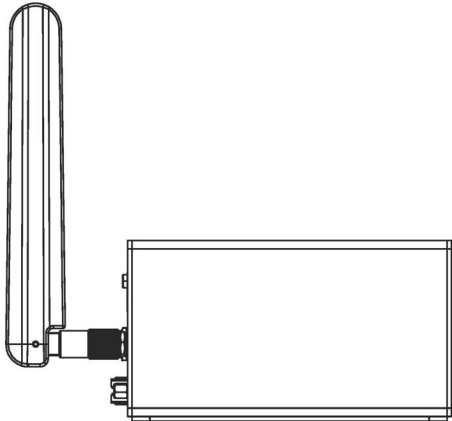
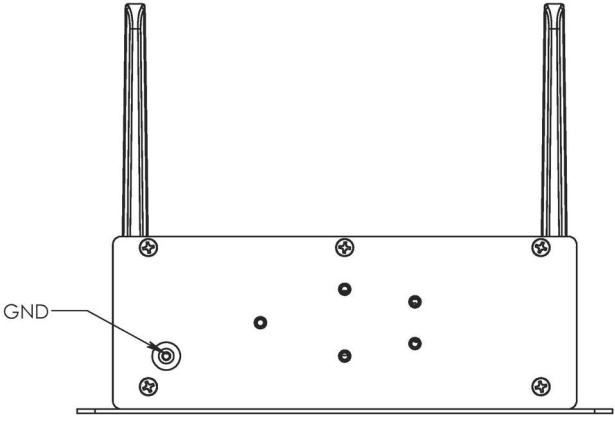
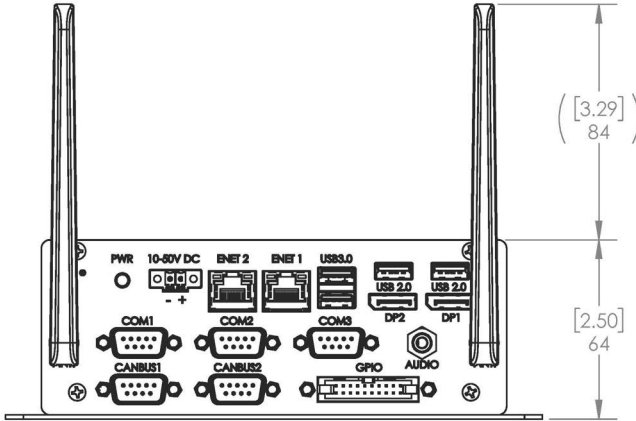
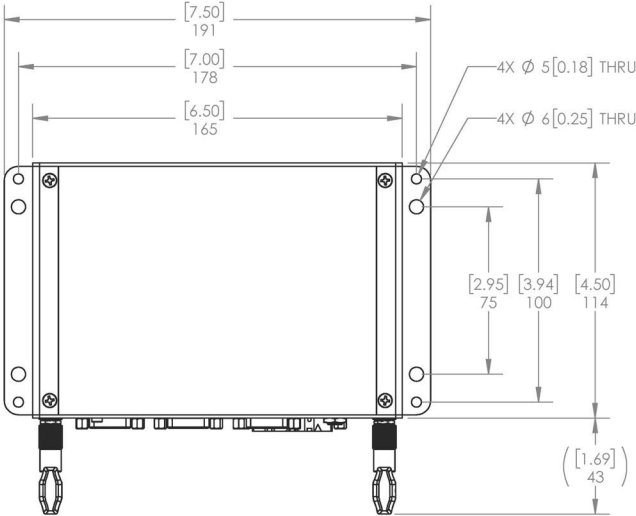

**Top measurements are in inches.**

**Bottom measurement are in millimeters.**

## Appendix C. Warranty Information

Full warranty information is at <https://winsystems.com/company-policies/warranty/>.