

Features

- PC/104 compliant module
- Four serial ports with 16C554-compatible UART core
- Each serial channel supports:
 - 16 byte Tx and Rx FIFOs
 - CTS, RTS, DSR, DTR, RI and DCD
 - RS-232/422/485 signal levels
 - Programmable data rates up 115.2 kbps
- All 48 digital I/O lines support
 - Input, Output or Output with Read back
 - Interface with signals up to 30 volt
 - 12 mA sink current
- 24 of the 48 DIO lines support change-of-state event sense with selectable edge polarity
- Jumper selectable board I/O addresses
- -40° to +85°C operational temperature range
- +5 volt only operation
- Small size: 3.6 x 3.8 inches (90 x 96mm)
- Combines PCM-COM4A and PCM-UIO48-B



Product Description

WinSystems' PCM-SDIO combines both four serial and 48 digital I/O lines onto a single PC/104 module. This can eliminate one board in a stack without sacrificing any features or benefits. The digital portion is further enhanced since its I/O can interface with up to 30 volt signals.

The controller is based upon a FPGA with both 16C554 UART and WS16C48-compatible cores. It supports various programmable input/output and interrupt configurations.

The board is shipped in a standard configuration that supports RS-232, RS-422, and RS-485 on all four channels. Only +5 volts is required since the interface chips generate the positive and negative voltages required for RS-232 signal levels.

The RS-422/485 configuration provides separate balanced transmit and receive signal pairs. Both the RS-422/485 transmitter and receiver lines have jumper enabled termination resistors for impedance matching and biasing.

The PCM-SDIO also has 48 lines of digital I/O. The major feature of this card is its ability to monitor 24 of the 48 lines for both rising and falling digital edge transitions, latch them and then interrupt the host processor notifying that a change-of-input status has occurred. This is an efficient way of signaling the CPU of real-time events without the burden of polling the digital I/O points.

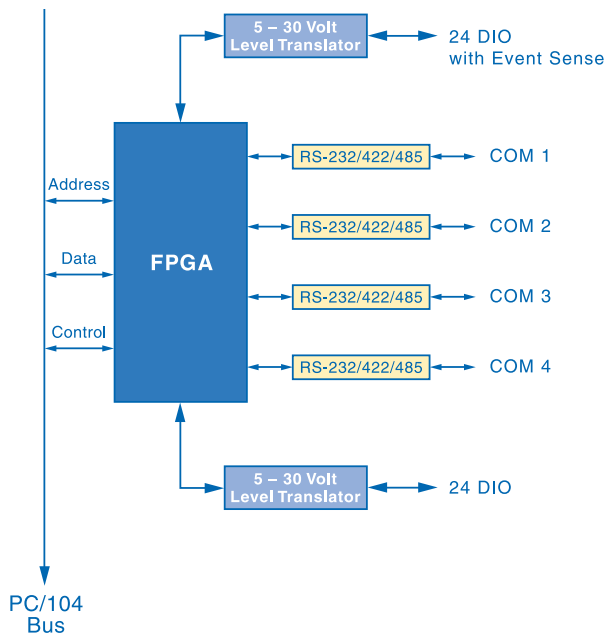

PCM-SDIO Block Diagram

PCM-SDIO - PC/104 Quad Serial and 48-line Digital I/O

The WS16C48 controller supports 48 digital I/O lines addressed through six contiguous registers. A six-bit Write Mask register allows the user to disable Writes on a byte basis to configure the group as a "Read Only" port. Each I/O line is individually programmable for input, output, or output with Read back operation. The input lines are connected so the current status of its output port can be read from the corresponding input port (Read back). If the port is used as input only, then the corresponding output port bit must be cleared.

Each output channel is latched and has an open collector driver (with a pull-up resistor) capable of sinking 12mA of current. This allows direct control of up to 48 opto-isolated signal conditioning to a single card for high density I/O support.

There is a FET on each digital I/O line with an open-drain configuration that can support from 5 to 30 volts.

Event Sense Operation - The WS16C48 supports 24 event sense lines to generate an interrupt when an event occurs. This means that 24 lines of the digital I/O can sense a positive or negative transition on the input. Transition polarity is programmable and enabled on a bit-by-bit basis. Each line's transition is latched by the event so that even short duration pulses will be recognized.

The PCM-SDIO has easy-to-use 0.100" box header connectors to access the serial and digital I/O. WinSystems has optional cables or a user can make their own.

Interrupts - Interrupts are generated on error conditions or receive/transmit buffer status for each of the serial channels. Each of the four channels are routed to a FPGA and then to the PC/104 Bus connector. The event sense lines of the digital I/O can generate interrupts as well. The FPGA offers extreme flexibility with interrupt selection, IRQ assignment, and interrupt sharing.

The PCM-SDIO also contains a Read Only Interrupt Status Register to allow quick identification of the UART channel(s) needing service.

WinSystems - The PCM-SDIO is a replacement and is pin compatible for the PCM-UIO48A and PCM-UIO48A-G as well as for WinSystems' PCM-COM4A.

The PCM-SDIO supports Linux, Windows XP, and DOS. Free drivers are downloaded from our website.

OEM Configurations - If you need a special configuration, contact a WinSystems factory application engineer to discuss your requirement.

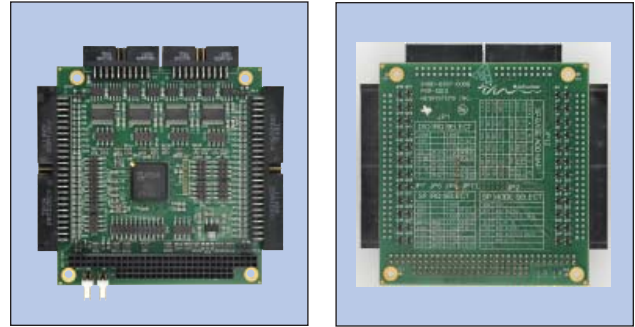

Front and Back Picture of PCM-SDIO

Technical Specifications

Electrical

PC/104 Bus, 8- or 16-bit stackthrough
48 Digital I/O lines, TTL compatible
4 Asynchronous serial channels the support RS-232/422/
485 interface levels
Data rate up to 115.2 kbps

Power

+5V \pm 5% at 250 mA (typ.)

Environmental

Operational from -40° to +85°C
RoHS compliant Yes

Mechanical

Dimensions 3.6 x 3.8 inches (90 x 96mm)
Weight 3.2 oz (90.7 gm)

Ordering Information

PCM-SDIO-144 Four serial channel and 48-line digital I/O
card PC/104 interface

Cables

CBL-115-4 4-ft., Opto rack interface
CBL-129-4 4-ft., ribbon cable, 50 pin. Both ends
with 50-pin socket termination
CBL-173-G-1-1.0 20-pin ribbon cable to two 9-pin,
male D sub connectors

WinSystems reserves the right to make changes to products and/or documentation without further notification.

Product names of other companies may be trademarks of their respective companies.

