

WinSystems®

PC/104 MODULE

PCM-DSPIO Dual Serial and Parallel I/O

FEATURES

- PC/104 compliant dual serial/parallel I/O module
- Two independent 8250-compatible serial channels
- 16-byte transmit FIFO on each channel
- 16-byte receive FIFO with error flags
- Modem control signals: CTS, RTS, DSR, DTR, RI, and DCD on each channel
- Programmable serial interface characteristics for each channel
 - 5-, 6-, 7-, or 8-bit character lengths
 - Even, odd, or no parity generation and checking
 - 1, 1.5, or 2 stop bits
 - Local internal loopback for diagnostics
- RS-232 and optional RS-485, RS-422 or J1708 electrical interface levels on both channels
- Asynchronous data rates to 115,200 bps
- Software programmable baud rate generator
- PC-compatible parallel printer interface
- Jumper selectable board I/O address
- +5 volt only operation
- 8-bit or 16-bit PC/104 stackthrough connector
- Small size: 3.6" x 3.8" (90mm x 96mm)
- Operating temperature: -40°C to +85°C

The PCM-DSPIO dual serial and printer interface adds two PC-compatible COM ports and one parallel printer port to a PC/104 expandable system. Both serial channels support RS-232. As an option, RS-422/485 plus the Society of Automotive Engineers (SAE) J1708 interface levels are also supported. Because of its compatibility with the standard PC serial and parallel ports, the PCM-DSPIO is supported by operating systems, drivers, utilities and 3rd party libraries.

FUNCTIONAL CAPABILITY

PC/104 Interface - The PCM-DSPIO is I/O mapped to various jumper selectable locations. Each serial channel requires 8 port addresses and is independently decoded within the I/O map from COM1 to COM8. The bidirectional parallel port requires 4 port addresses and can be jumper selected for LPT1 or LPT3.

The PCM-DSPIO card is available with either an 8-bit or 16-bit PC/104 stackthrough connector for additional interrupt support.

Serial Controller - A 16C552 serves as the serial communication controller. It has two independent, asynchronous channels that are 8250 hardware compatible. The unit contains on-chip software programmable baud rate generators selectable through 115,200 bits per second. Each channel has a 16-byte transmit and receive

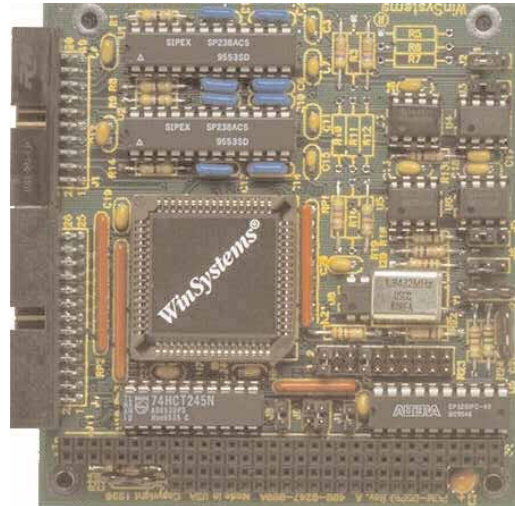

First-In First-Out (FIFO) buffer for use with high speed data communication applications.

Each channel will support 5-, 6-, 7- or 8-bit characters with even, odd or no parity generation and checking. It will handle 1, 1.5, or 2 stop bits. Each channel can be set up to provide internal diagnostics such as loopback and echo mode on the data stream.

Electrical Interface Levels - The board is shipped in a standard configuration that supports RS-232. Only +5 volts is required for the module since it uses an interface chip with a charge pump to generate the plus and minus voltages required for RS-232 levels.

Optionally, RS-422/485 electrical levels can be supported on both serial channels. The RS-422/485 configuration provides separate balanced transmit and receive signal pairs. For RS-485 multidrop lines, one signal pair can be used for "party line" networks.

Both the RS-422/485 transmitter and receiver lines permit user-installable termination resistors for impedance matching and biasing.

WinSystems' CK-75176-2 chip kit can be ordered for each channel that contains two 75176B devices. The parts can be easily installed by the user.

J1708 - The PCM-DSPIO can be ordered with the serial channels configured to support the SAE J1708 electrical standard and is designated PCM-J1708. This is a serial data communications link between micro-computer systems in heavy duty vehicle applications to

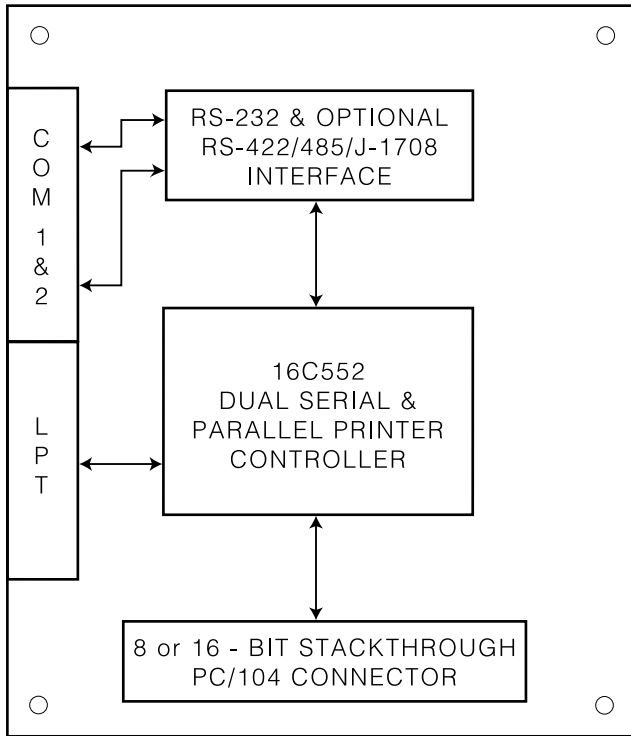

PCM-DSPIO BLOCK DIAGRAM

share data cost effectively among stand-alone modules. SAE J1708 is a modification of the RS-485 standard with additional passive termination for transient and EMI suppression at the module.

Serial I/O Connector - Both serial channels are configured as Data Terminal Equipment (DTE) and wired to a 20-pin right angle connector. WinSystems offers the optional CBL-173-1 which adapts each RS-232 serial channel pair to two standard 9-pin male "D" type connectors.

Parallel I/O - The 16C552 chip also provides a direct 26-pin Centronics parallel I/O interface from the PCM-DSPIO. The port is wired as a parallel printer port but can be used for other devices. The 8 data lines are bi-directional with a 24 mA sink capability. The additional handshake lines are dedicated with 5 bits as input only and 4 bits as output only.

The parallel signal lines are wired to a 26-pin right angle connector. The optional WinSystems' CBL-101-3 provides a 3 foot long adapter cable designed to convert a 26-pin ribbon cable to a 25-pin female "D" type connector with strain relief.

Interrupts - Interrupts are generated on error conditions or receive/transmit buffer status for each of the serial channels or from the parallel I/O. Each of the 3 interrupt request channels from the 16C552 can be routed to the PC/104 Bus connector. The PCM-DSPIO supports IRQ channels 2, 3, 4, 5, and 7 on the 8-bit PC/104 connector plus IRQ channels 10, 11, 12, and 15 on the 16-bit PC/104 connector.

Custom Configurations - For OEM applications, the PCM-DSPIO can be shipped from the factory with your specific RS-232/422/485 or J1708 configuration. Contact the factory for pricing and delivery.

SPECIFICATIONS

Electrical

PC/104 Bus: 8- or 16-bit, stackthrough
 Serial: 2 RS-232 asynchronous channels.
 Optional RS-422/485 with the CK-75176-2 installed per channel
 Baud rates: 50, 110, 150, 300, 600, 1200, 2400, 4800, 7200, 9600, 19.2K, 38.4K, 56K, 115.2K
 Parallel: Bi-directional PC-compatible printer port
 Vcc = +5V ±5% @ 90mA typ. RS-232 channels
 +5V ±5% @ 120mA typ. RS-422 channels

Mechanical

Dimensions: 3.6" x 3.8" (90mm x 96mm)
 PC board: 2 layer FR4 epoxy glass with screened component legend

Connectors

Serial: One, 20-pin 0.100" grid
 Parallel: One, 26-pin 0.100" grid
 PC/104: 64-pin, 0.100" (32-pin double row)
 40-pin 0.100" (20-pin double row)

Environmental

Operating Temperature: -40° to +85° Celsius
 Non-condensing relative humidity: 5% to 95%

ORDERING INFORMATION

PCM-DSPIO-8	Dual Serial and Parallel, 8-bit PC/104 module
PCM-DSPIO-16	Dual Serial and Parallel, 16-bit PC/104 module
PCM-J1708	Dual SAE J1708 interface module
CBL-101-3	26-pin ribbon to 25-pin male "D" adapter to a parallel printer
CBL-173-1	20-pin ribbon to two male 9-pin "D"
CK-75176-2	RS-422/485 chip kit for one channel

